



MALTEP

Edition 09-2017



Earthing, Bonding and Lightning Protection



Earthing
Equipotential Bonding
Lightning Protection
Exothermic Welding



MALTEP is a French company founded in 2004 and based in Alsace, in the heart of Europe, we specialize in the manufacturing and distribution of electrical bonding and protective equipment.

Since 2015, our company integrated the ESP (Electrical Safety Products) business unit of the French group NOVARC. We carry electrical earthing and bonding projects in partnership with most renowned actors within the electrical field, at both national and international level.

Our products are manufactured according to the requirements of European and international standards.

They are used in a wide range of applications such as electrical and networks engineering, telecommunications networks, railway networks, wind turbines, nuclear power plants, airports, public works, etc.

Our wide range of standard products, outlined in this catalog, are complemented by our on-demand product range based on your design, drawings or specifications, allowing us to cover all of our customers' needs for their most complex projects.

We are driven by the constant desire to fully satisfy our customers with quality, price and lead time, our team is at your full disposal to advise you and accompany you in all the aspects of your projects.



Copper based products manufacturing



Warehouse



Sea worthy packaging

Earthing and Bonding Hardware

Bar holders	30
Bimetallic copper/aluminium cable lugs	24
Copper alloy bolts	35
C crimp connectors	27
Cable clamps	33
Clamps for rebar	23
Copper bonded steel earth rods	17, 18
Copper earth rods	19
Copper flat braided mesh	9
Copper round braided mesh	9
Copper round braided mesh, PVC coated	8
Copper/aluminium bi-metallic plates	30
Copper/Aluminium bi-metallic washers	28
Disconnecting links	20
Earth clamp	31
Earth grids	19
Earth rod clamps	18
Earthing collars	22
Equipotential bonding bars	21
Fixed earthing terminal	23
Flat braided mesh, PVC coated	8
Flexible tinned copper earth braids	10, 11
Fully assembled split bolt connectors	28
Hard drawn and round conductors	15
Hard drawn copper bar	14
Heat shrink tubes	32
Hot-dip galvanized steel cables	12
Insulated green/yellow cables	13
Insulators	20
Miscellaneous clamps	26
Miscellaneous copper alloy clamps	26
Perforated bars	14
Polyamide zip ties	36
Split bolt connectors	29
Stainless steel earth rods	16
Stainless steel ribbon ties	37
Stainless steel bolts	34
Stainless steel zip ties	36
Stranded bare copper cables	12
Threaded bars	14
Tubular compression lugs	25
Winged earth clamp	30

Power substation hardware

C crimp connectors	43
Cable holder	42
Copper/Aluminium bi-metallic plate and washer	43
Coupler for bonding cable	42
Earth clamp, RTE CNER	41
Straight compression lugs with long barrel	42
Tinned copper braided mesh	43

Lightning Protection



Anti-vandal metal guard	51
Bitumen felt roll	52
Cast inspection pit	50
Crows foot clamp	50
Early streamer emission (ESE) air terminal	54
Free standing air terminal support	47
Holdfast for conductors support on flat roof	52
Insulated plastic clips for down conductors	53
Lightning air terminal	47
Lightning flash counter	51
Lightning rod	46
Protective spark gap	50
Push in clips for round conductors	52
Rod base	47
Sealing tape	50
Square Clamp	48, 49
Stainless steel clip for flat conductor	53
Stapples and anchors for down conductors	53
Test joint	51

Exothermic welding

Bypass tape conductor to cable weld	71
Cable on horizontal steel surface	76
Cable on top of earth rod weld	69
Cable on vertical steel surface	75
Cable to tape conductor weld	70
Exothermic welding for 30x2mm tape conductors	61
Exothermic welding for end to end cables	63
Exothermic welding for end to end cables	65
Exothermic welding for galvanized steel conductors	62
Exothermic welding for tee cables	64
Horizontal cross weld	67
Horizontal end to end tape conductor weld	72
Horizontal tee/cross tape conductor weld	73
On demand welding	77
Overlap horizontal cross weld	68
Overview	56
Selection Guide	57
Side by side horizontal parallel weld	66
Tape conductor on vertical surface weld	74
Welding kit for cables in parallel	60
Welding kit for cables on steel surface	60
Welding metal and accessories	59
Welding procedure	58





Flat tinned copper braided mesh, PVC Coated

Cross Section (mm ²)	Nominal dimensions (mm)	 (ml)	 (Kg/100m)	Part Number
10 mm ²	12 x 3.5	100	12	TPE10PVC
16 mm ²	17 x 3.5	100	18	TPE16PVC
25 mm ²	27 x 4	50	29	TPE25PVC
35 mm ²	29 x 4	50	39	TPE35PVC
50 mm ²	28 x 7	50	56	TPE50PVC
75 mm ²	33 x 8	25	82	TPE75PVC

Alternative cross sections and dimensions available on-demand.





Round tinned copper braided mesh, PVC Coated

Cross Section (mm ²)	Diameter over insulation (mm)	 (ml)	 (Kg/100m)	Part Number
10 mm ²	7	100	12	TRE10PVC
16 mm ²	8	100	17	TRE16PVC
25 mm ²	10	50	29	TRE25PVC
35 mm ²	12	50	39	TRE35PVC
50 mm ²	13	50	55	TRE50PVC
75 mm ²	15	25	81	TRE75PVC
95 mm ²	18	25	101	TRE95PVC
120 mm ²	21.5	drum	127	TRE120PVC



Alternative cross sections and dimensions available on-demand.



Flat tinned copper braided mesh				
Cross Section (mm ²)	Nominal dimensions (mm)	 (ml)	 (Kg/100m)	Part Number
2.5 mm ²	4.5 x 1.3	100	2.5	TPE25/10
5 mm ²	8 x 1.4	100	5	TPE5
10 mm ²	12 x 1.8	25 & 50 & 100	10	TPE10
16 mm ²	15 x 2	25 & 50 & 100	16	TPE16
25 mm ²	22 x 2.3	25 & 50	25	TPE25
35 mm ²	27 x 2.8	25 & 50	35	TPE35
50 mm ²	30 x 3.5	25 & 50	50	TPE50
70 mm ²	30 x 5	25	70	TPE70
75 mm ²	33 x 5	25	75	TPE75
95 mm ²	38 x 5	25	95	TPE95
120 mm ²	40 x 6	10	120	TPE120
150 mm ²	50 x 6	10	150	TPE150
185 mm ²	50 x 8	10	185	TPE185

Alternative cross sections and dimensions available on-demand.



Round tinned copper braided mesh				
Cross Section (mm ²)	Nominal diameter (mm)	 (ml)	 (Kg/100m)	Part Number
6 mm ²	4	50 & 100	6	TRE6
10 mm ²	5	50 & 100	10	TRE10
16 mm ²	6	25 & 50	16	TRE16
25 mm ²	8	25 & 50	25	TRE25
35 mm ²	9	25	35	TRE35
50 mm ²	11	25	50	TRE50
70 mm ²	13	25	70	TRE70
75 mm ²	13.5	25	75	TRE75
95 mm ²	15	25	95	TRE95
120 mm ²	17.5	drum	120	TRE120

Alternative cross sections and dimensions available on-demand.



Table of correspondances	
Bolt	Hole diameter (mm)
M5	5.3
M6	6.5
M8	8.5
M10	10.5
M12	13
M14	15
M16	17
M18	19
M20	21
M22	23
M24	25
M27	29
M30	32
M33	35
M36	39

Within a short lead-time, we can manufacture on-demand flexible tinned copper earth braids according to your own drawings and specification, with a cross section ranging from 6 to 240mm² and more.

For your quotation request, if you don't have a drawing, please provide us with:

- The type of the braided mesh (round or flat)
- The cross section of the braided mesh
- The length between axis (from 50mm up to several meters)
- The quantity for each type
- The connection holes diameter (see table of correspondances)

New: Online earth braids configurator available on www.maltep.com/configurator

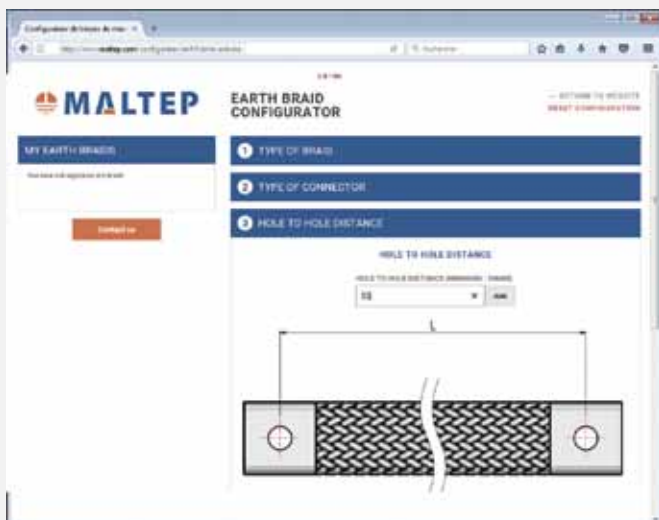

Available on mobile and tablet!



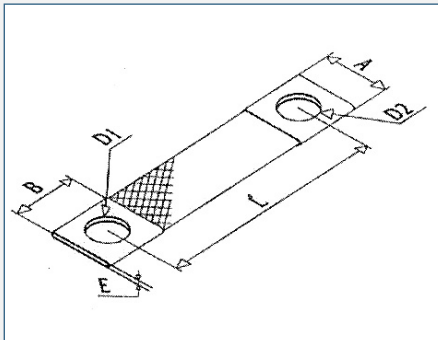

Flexible tinned copper earth braids

Manufactured from flat tinned Copper Braided Mesh (strands of 15/100 or 20/100mm) with crimped and punched tinned copper connectors at both ends

Earth braid Cross section (mm ²)	Holes Dia. (mm)		Length between axis (mm) L	Connectors dimensions (mm)			50 - 100	Kg/100	Part Number
	D1	D2		A	B	E			
10 mm ²	6.5	6.5	100	14	15	3.5	50 - 100	1.63	TME10100-6
10 mm ²	6.5	6.5	150	14	15	3.5	50 - 100	2.11	TME10150-6
10 mm ²	6.5	6.5	200	14	15	3.5	50 - 100	2.59	TME10200-6
10 mm ²	6.5	6.5	250	14	15	3.5	50 - 100	3.07	TME10250-6
10 mm ²	6.5	6.5	300	14	15	3.5	50 - 100	3.55	TME10300-6

16 mm ²	8.5	8.5	100	17	17	4	50 - 100	2.52	TME16100-8
16 mm ²	8.5	8.5	150	17	17	4	50 - 100	3.20	TME16150-8
16 mm ²	8.5	8.5	200	17	17	4	50 - 100	3.88	TME16200-8
16 mm ²	8.5	8.5	250	17	17	4	50 - 100	4.56	TME16250-8
16 mm ²	8.5	8.5	300	17	17	4	50 - 100	5.24	TME16300-8
16 mm ²	8.5	8.5	350	17	17	4	50 - 100	5.92	TME16350-8
16 mm ²	8.5	8.5	400	17	17	4	50 - 100	6.60	TME16400-8

25 mm ²	8.5	8.5	100	23	25	4	25 - 50	5.16	TME25100-8
25 mm ²	8.5	8.5	150	23	25	4	25 - 50	6.36	TME25150-8
25 mm ²	8.5	8.5	200	23	25	4	25 - 50	7.56	TME25200-8
25 mm ²	8.5	8.5	250	23	25	4	25 - 50	8.76	TME25250-8
25 mm ²	8.5	8.5	300	23	25	4	25 - 50	9.96	TME25300-8
25 mm ²	8.5	8.5	350	23	25	4	25 - 50	11.16	TME25350-8
25 mm ²	8.5	8.5	400	23	25	4	25 - 50	12.36	TME25400-8

35 mm ²	10	10	100	27	25	4.2	25 - 50	6.70	TME35100-10
35 mm ²	10	10	150	27	25	4.2	25 - 50	8.42	TME35150-10
35 mm ²	10	10	200	27	25	4.2	25 - 50	10.12	TME35200-10
35 mm ²	10	10	250	27	25	4.2	25 - 50	11.85	TME35250-10
35 mm ²	10	10	300	27	25	4.2	25 - 50	12.56	TME35300-10
35 mm ²	10	10	350	27	25	4.2	25 - 50	15.28	TME35350-10
35 mm ²	10	10	400	27	25	4.2	25 - 50	17.00	TME35400-10

50 mm ²	10	10	100	33	30	5	25	9.85	TME50100-10
50 mm ²	10	10	150	33	30	5	25	12.15	TME50150-10
50 mm ²	10	10	200	33	30	5	25	14.50	TME50200-10
50 mm ²	10	10	250	33	30	5	25	16.80	TME50250-10
50 mm ²	10	10	300	33	30	5	25	19.10	TME50300-10
50 mm ²	10	10	350	33	30	5	25	21.45	TME50350-10
50 mm ²	10	10	400	33	30	5	25	23.75	TME50400-10
50 mm ²	10	10	500	33	30	5	25	28.40	TME50500-10

70 mm ²	12	12	150	32	30	5.5	25	15.75	TME70150-12
70 mm ²	12	12	200	32	30	5.5	25	19.70	TME70200-12
70 mm ²	12	12	250	32	30	5.5	25	22.40	TME70250-12
70 mm ²	12	12	300	32	30	5.5	25	25.70	TME70300-12
70 mm ²	12	12	400	32	30	5.5	25	32.35	TME70400-12
70 mm ²	12	12	500	32	30	5.5	25	39.00	TME70500-12



Stranded bare copper cable

Cross Section (mm ²)	Composition (number and strand dia.)	(Kg/m)	(ml)	Part Number
6 mm ²	7 x 1.07 mm	0.054	100 & drums	CCR6
10 mm ²	7 x 1.43 mm	0.087	100 & drums	CCR10
16 mm ²	7 x 1.71 mm	0.144	25 & 50 & drums	CCR16
25 mm ²	7 x 2.13 mm	0.225	25 & 50 & drums	CCR25
29 mm ²	19 x 1.40 mm	0.267	50 & drums	CC29
35 mm ²	7 x 2.50 mm	0.305	50 & drums	CCR35
50 mm ²	19 x 1.77 mm	0.420	50 & drums	CCR50
70 mm ²	19 x 2.14 mm	0.610	50 & drums	CCR70
75 mm ²	19 x 2.25 mm	0.647	50 & drums	CCR75
95 mm ²	19 x 2.52 mm	0.830	50 & drums	CCR95
120 mm ²	19 x 2.94 mm	1.040	drums	CCR120
120 mm ²	37 x 2.05 mm	1.065	drums	CCR120-37
150 mm ²	19 x 3.24 mm	1.260	drums	CCR150
150 mm ²	37 x 2.21 mm	1.260	drums	CCR150-37
185 mm ²	37 x 2.50 mm	1.620	drums	CCR185
240 mm ²	61 x 2.28 mm	2.200	drums	CCR240
300 mm ²	61 x 2.50 mm	2.650	drums	CCR300

Alternative packing options, drums, sea worthy cable drums available on demand.



Hot-dip galvanized steel cable

Cross Section (mm ²)	Composition (number and strand dia.)	(Kg/m)	(ml)	Part Number
35 mm ²	19 x 1.6 mm	0.31	100 & drums	CG35
50 mm ²	19 x 2 mm	0.46	100 & drums	CG50
70 mm ²	19 x 2.20 mm	0.6	50 & drums	CG70
95 mm ²	19 x 2.55 mm	0.8	50 & drums	CG95
130 mm ²	7x3.2 + 12x2.80 mm	1.09	drums	CG130

Semi-rigid insulated yellow/green stranded copper cable (VR)

Cross Section (mm ²)	Composition (number and strand dia.)	(Kg/m)	(ml)	Part Number
6 mm ²	19 x 0.64 mm	0.07	100 & drums	CC6VJ
10 mm ²	49 x 0.51 mm	0.11	100 & drums	CC10VJ
16 mm ²	7 x 1.40 mm	0.17	50 & drums	CC16VJ
25 mm ²	19 x 1.40 mm	0.26	50 & drums	CC25VJ
35 mm ²	7x 2.14 mm	0.36	50 & drums	CC35VJ
50 mm ²	19 x 1.78 mm	0.48	50 & drums	CC50VJ
70 mm ²	19 x 2.14 mm	0.68	drums	CC70VJ
95 mm ²	19 x 2.50 mm	0.94	drums	CC95VJ
120 mm ²	37 x 2.03 mm	1.18	drums	CC120VJ
150 mm ²	37 x 2.27 mm	1.44	drums	CC150VJ
185 mm ²	37 x 2.52 mm	1.79	drums	CC185VJ
240 mm ²	61 x 2.24 mm	2.38	drums	CC240VJ



Alternative packing options, drums, sea worthy cable drums available on demand.

Flexible insulated yellow/green stranded copper cable (VK)

Cross Section (mm ²)	Composition (number and strand dia.)	(Kg/m)	(ml)	Part Number
6 mm ²	84 x 0.3 mm	0.07	100& drums	CCS6VJ
10 mm ²	80 x 0.4 mm	0.11	100 & drums	CCS10VJ
16 mm ²	112 x 0.41 mm	0.17	50 & drums	CCS16VJ
25 mm ²	204 x 0.395 mm	0.25	50 & drums	CCS25VJ
35 mm ²	286 x 0.395 mm	0.34	50 & drums	CCS35VJ
50 mm ²	408 x 0.395 mm	0.46	50 & drums	CCS50VJ
70 mm ²	356 x 0.5 mm	0.68	drums	CCS70VJ
95 mm ²	485 x 0.5 mm	0.94	drums	CCS95VJ
120 mm ²	614 x 0.5 mm	1.18	drums	CCS120VJ

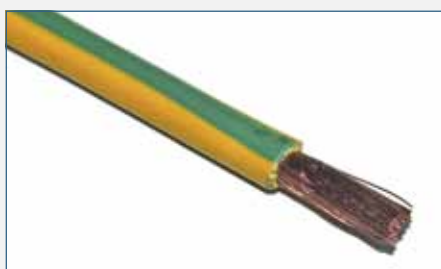

Alternative packing options, drums, sea worthy cable drums available on demand.



Hard drawn copper bar

Dimensions (mm)	Material Composition	(Kg/m)	(ml)	Part Number
25 x 3	Pure copper, 1/2 state, H12 hardness	0.668	3	CU253
30 x 4	Pure copper, 1/2 state, H12 hardness	1.068	3	CU304
40 x 5	Pure copper, 1/2 state, H12 hardness	1.780	3	CU405
50 x 5	Pure copper, 1/2 state, H12 hardness	2.225	3	CU505
80 x 5	Pure copper, 1/2 state, H12 hardness	3.56	3	CU805
100 x 5	Pure copper, 1/2 state, H12 hardness	4.45	3	CU1005
100 x 10	Pure copper, 1/2 state, H12 hardness	8.90	3	CU10010

Alternative dimensions, length of 4 or 6ml or alternative metallurgic states available on demand.

Perforated copper bars, length of 1750mm

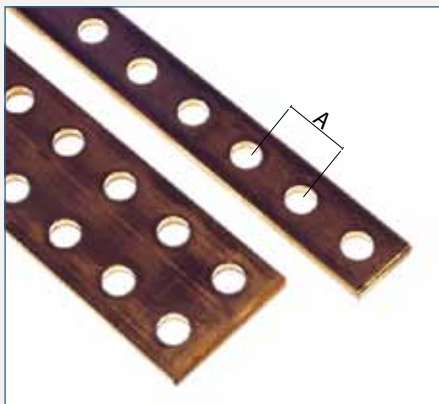

Dimensions (mm)	Holes dia. (mm)	Distance between axes A (mm)	(Kg)	(ml)	Part Number
Single perforation					
25 x 5	10.5	25	1.66	1	PT1750-10/255
Double perforation					
50 x 5	10.5	25	3.32	1	PT1750-10/505
80 x 5	10.5	25	5.30	1	PT1750-10/805
100 x 5	10.5	25	6.64	1	PT1750-10/1005



Threaded copper bars, length of 990mm

Dimensions (mm)	Holes dia. (mm)	Distance between axes A (mm)	(Kg)	(ml)	Part Number
20 x 5	M6	25	0.76	1	PT990-M6/20X5
32 x 5	M6	25	1.22	1	PT990-M6/32X5



On demand manufacturing

We can manufacture a wide range of hard drawn copper or 304/316 stainless steel bars according to your drawings or specifications.



Round conductors

Standard packing in coils

Compliant with IEC EN62561-2, for equipotential bonding and lightning protection installations.

Dimension (mm)	Material	(Kg/m)	(ml)	Part Number
Dia. 6	Annealed electrolytic copper	0.25	100 - 120	TR6100
Dia. 8	Annealed electrolytic copper	0.448	50 - 60	TR8100
Dia. 8	Tinned annealed electrolytic copper	0.448	70	TRE8100
Dia. 8	3m Annealed hard drawn electrolytic copper bar	0.448	3	TR8003
Dia 8	Aluminium	0.135	150 -160	TRAL8150
Dia 10	Aluminium	0.215	100 -110	TRAL10100
Dia. 8	Hot-dip galvanized steel	0.395	100-130	TRG8130
Dia. 8	304 Stainless steel	0.395	100-130	TRI8130
Dia. 8	316 Stainless steel	0.395	100-110	TRI8130-A4
Dia. 10	316 Stainless steel	0.617	100-110	TRI10100-A4



Flat conductors

Standard packing in coils

Compliant with IEC EN62561-2, for equipotential bonding and lightning protection installations.

Dimensions (mm)	Material	(Kg/m)	(ml)	Part Number
30 x 2	Annealed electrolytic copper	0.534	50	CU302
30 x 2	Tinned annealed electrolytic copper	0.534	50 - 80	CUE302
30 x 2	304 Stainless steel	0.471	80	I302
30 x 2	316 Stainless steel	0.471	80	I302-A4
30 x 3.5	316 Stainless steel	0.825	60	I3035-A4
30 x 3	Aluminium	0.243	80	AL303
30 x 3.5	70µm Hot-dip galvanized steel	0.83	30 - 60	AG3035
40 x 4	70µm Hot-dip galvanized steel	1.28	40	AG404
40 x 5	70µm Hot-dip galvanized steel	1.58	30	AG405



Stainless steel earth rods

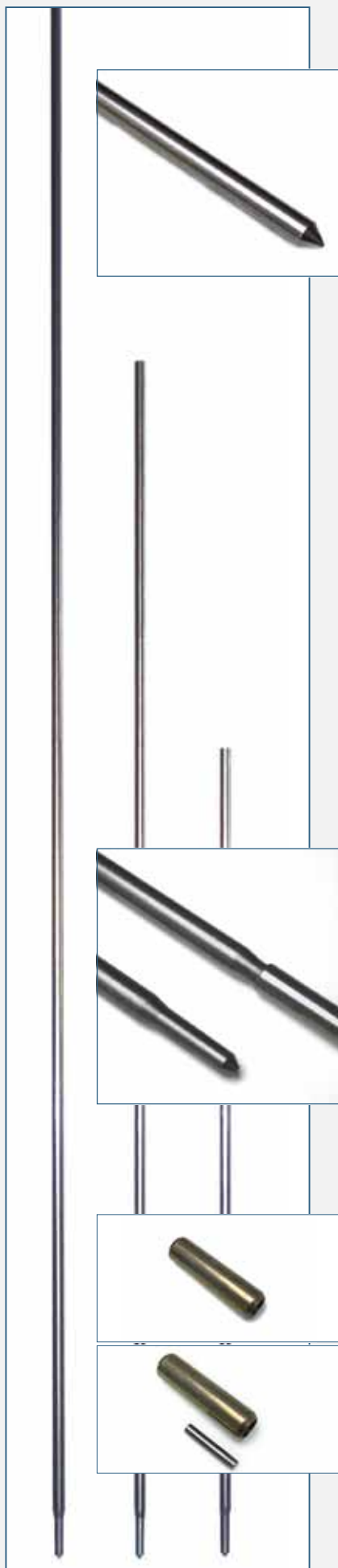

Non-extensible stainless steel earth rods

Made of Z33 C13 stainless steel, one end is pointed to ease driving into ground during installation

Length (mm)	Nominal dia. (mm)	Real dia. (mm)	(Kg)		Part Number
1000	16	16	1.50	5	PI1610
1500	16	16	2.25	5	PI1615
2000	16	16	3.00	5	PI1620

On demand : specific manufacturing and alternative length possible

Non-extensible 316(A4) stainless steel earth rods

Made of 316 stainless steel, one end is pointed to ease driving into ground during installation. Compliant with IEC EN62561-2

Length (mm)	Nominal dia. (mm)	Real dia. (mm)	(Kg)		Part Number
1000	16	16	1.50	1	PI1610-A4
1500	16	16	2.25	1	PI1615-A4
2000	16	16	3.00	1	PI1620-A4

On demand : specific manufacturing and alternative length possible

Extensible 316(A4) stainless steel earth rods

Made of Z33 C13 stainless steel as recommended per the French electrical company EDF. With one bore end to connect the next earth rods and the other pointed end to ease driving into ground during installation.

Length (mm)	Nominal dia. (mm)	Real dia. (mm)	(Kg)		Part Number
1000	16	16	1.50	5	PI1610A
1500	16	16	2.25	5	PI1615A
2000	16	16	3.00	5	PI1620A

Driving head (to protect the end during driving of the earth rod into ground)

Designation	(Kg)		Part Number
Earth rod with a diameter of 16 or 19mm	0.40	5	BOU34
For extensible earth rod with a diameter of 16 or 19mm	0.46	5	BOU34A

250µm copper-bonded steel earth rods

The core is made with highly mechanical resistant steel bonded with a minimum thickness of 254µm electrolytic copper, manufactured according to the UL SPEC 467 norm.

Standard earth rods

One end is pointed to ease driving into ground during installation

Length (mm)	Nominal diameter (mm)	Real diameter (mm)	(Kg)		Part Number
1000	16	14.2	1.30	5	PC5810
1500	16	14.2	1.90	5	PC5815
2000	16	14.2	2.55	5	PC5820
1000	19	17.2	1.80	5	PC3410
1500	19	17.2	2.70	5	PC3415
2000	19	17.2	3.70	5	PC3420

On demand : specific manufacturing and alternative length possible

Copper alloy earth rod coupler for standard earth rods

Designation	(Kg)		Part Number
5/8" (16mm) diameter	0.10	5	MC58
3/4" (19mm) diameter	0.15	5	MC34

Extensible earth rods using threaded coupler

Threaded at both ends to connect with the next earth rod using coupler. One end is pointed to ease driving into ground during installation.

Length (mm)	Nominal diameter (mm)	Real diameter (mm)	(Kg)		Part Number
1500	19	17.2	2.70	5	PC3415F

Copper alloy coupling for threaded earth rods

Designation	(Kg)		Part Number
19mm (3/4") diameter	0.15	5	MF34

Driving head for threaded earth rods

Designation	(Kg)		Part Number
19mm (3/4") diameter	0.12	5	VF34

Protective and insulated driving head

Protective and insulated driving head

Safely push your earth rod into ground with our isolated handle

Designation	(Kg)		Part Number
Protective insulated (17kV) handle, dimension 130x60mm, earth rod max. diameter of 24mm max. Provided with an integrated anvil.	0.54	1	ISPI

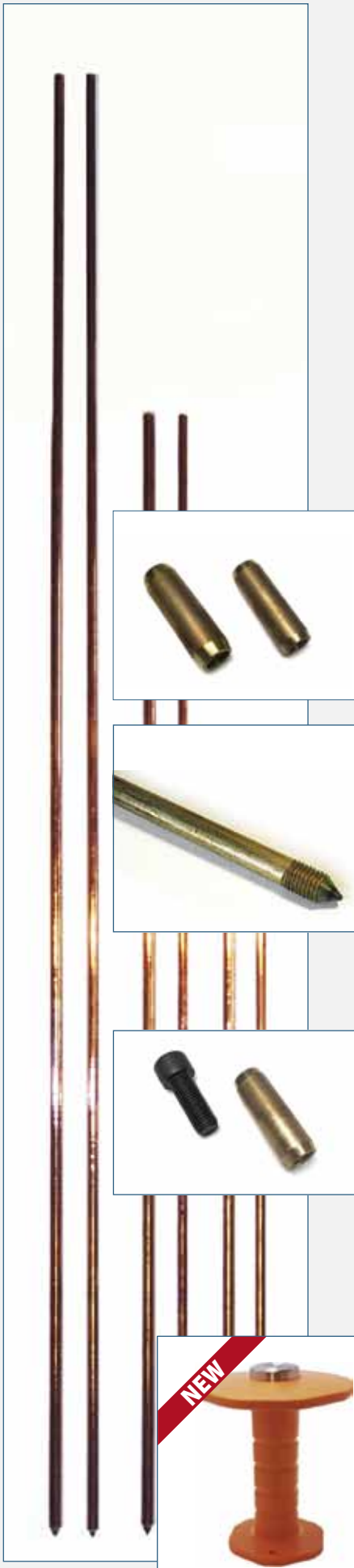

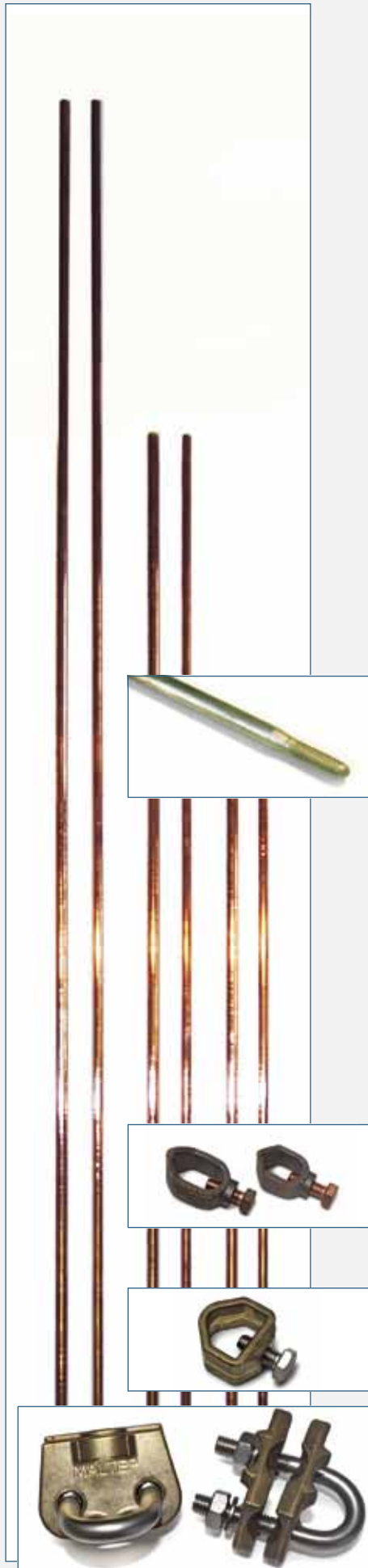

250µm copper-bonded steel earth rods

The core is made with highly mechanical resistant steel bonded with a minimum thickness of 254µm electrolytic copper, manufactured according to the UL SPEC 467 norm.

Self extensible earth rods

Threaded at one end to connect with the next earth rod by impingement. The other end is pointed to ease driving into ground during installation.

Length (mm)	Nominal diameter (mm)	Real diameter (mm)	(Kg)		Part Number
1000	19	17.2	1.80	5	PC3410A
1500	19	17.2	2.70	5	PC3415A

350µm copper-bonded steel earth rods

The core is made with highly mechanical resistant steel bonded with a minimum thickness of 350µm electrolytic copper as recommended per the French electrical company EDF.

350µm min. self extensible earth rods

Threaded at one end to connect with the next earth rod by impingement. The other end is pointed to ease driving into ground during installation.

Length (mm)	Nominal diameter (mm)	Real diameter (mm)	(Kg)		Part Number
1000	19	17.3	1.80	5	PCE3410A
1500	19	17.3	2.70	5	PCE3415A

Earth rod clamps

Earth rod clamps

Body made of copper alloy highly resistant to corrosion, processed or stainless steel screws.

Designation	(Kg)		Part Number
Clamp for 5/8" (16mm) dia. earth rod max. with cable from 16mm ² up to 70mm ² max.	0.06	5	COS1670Z
Clamp for 3/4" (18mm) dia. earth rod max. with cable from 25mm ² up to 95mm ² max.	0.08	5	COS2595Z
Clamp for 14mm to 20mm dia. earth rod with 30x8mm tape conductor max.	0.13	5	COS302
U bolt clamp for earth rod with a 20mm dia. max with a cable from 95mm ² to 240mm ² with an axial or radial path	0.34	5	COS95240



Copper earth grid with connecting band

Manufactured with pure electrolytic copper.
Full band on the length to ease connection.

Dimensions (mm)	Strip dimensions (mm)	Mesh (mm)	(Kg)		Part Number
2000 x 1000	3 x 3	115 x 55	8.00	1	GCB2010
1000 x 1000	3 x 3	115 x 55	4.00	1	GCB1010
500 x 1000	3 x 3	115 x 55	2.00	1	GCB0510

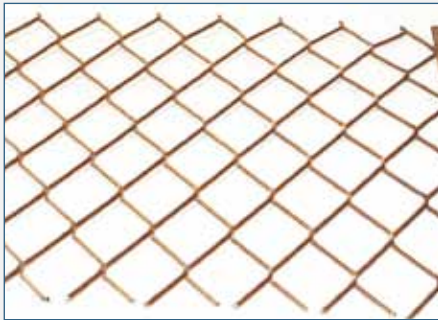

Copper earth grid without connecting band

Manufactured with pure electrolytic copper.

Dimensions (mm)	Strip dimensions (mm)	Mesh (mm)	(Kg)		Part Number
2000 x 1000	3 x 3	115 x 55	6.50	1	GC2010
1000 x 1000	3 x 3	115 x 55	3.20	1	GC1010
500 x 1000	3 x 3	115 x 55	1.60	1	GC0510



Copper earth plates

Manufactured with pure electrolytic copper.

Dimensions (mm)	Plate thickness (mm)	(Kg)		Part Number
2000 x 1000	2	35.00	1	PLC20102
2000 x 1000	3	53.00	1	PLC20103
2000 x 1000	4	71.00	1	PLC20104



On-demand pre-mounted earth grids and plates

We manufacture on-demand earth grids and plates equipped with earthing cables or tape conductors directly connected using exothermic welding.

Provide us with the following details when requesting a quote:

- the dimension of the earth grid or plate
- the cross section and the type of conductor to be welded
- the length of the conductors
- the required configuration and the quantity of conductors to be welded

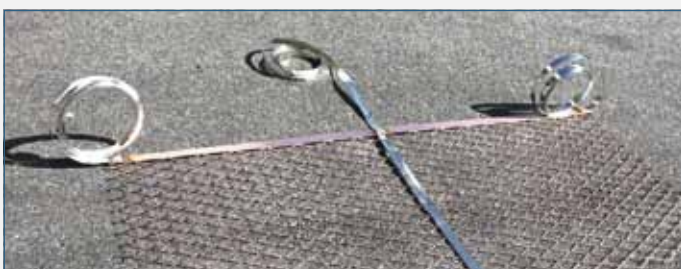

Low voltage insulators (female/female)

Fiberglass / polyester. Auto extinguishable (UL-94 standard) - Temperature : -40°C to +130°C.
Water absorption according to ASTM570: < 0.2% - Tracking resistance ASTMD2302 : W/min



Height (mm)	Internal thread and depth	Nominal voltage	Dielectric strength	Min. Start up Voltage	(Kg)		Part Number
25	M6 x 8	400V	7 KV	20 KV	0.02	25	IFFM625
35	M6 x 10	750 V	10 KV	40 KV	0.10	25	IFFM635
	M8 x 10	750 V	10 KV	40 KV	0.10	25	IFFM835
50	M8 x 15	1500V	12 KV	40 KV	0.20	10	IFFM850
	M10 x 15	1500V	12 KV	40 KV	0.20	10	IFFM1050
	M12 x 15	1500V	12 KV	40 KV	0.20	10	IFFM1250
80	M12 x 25	3600V	25 KV	50 KV	0.45	4	IFFM1280

On demand : Halogen free insulators available

Disconnecting links



Conductors range (mm ²)	Dimensions LxWxH	(Kg)		Part Number
16 - 35 mm ²	125 x 30 x 26	0.12	1 - 10	BT2535
16 - 70 mm ²	150 x 34 x 65	0.27	1	BT3570
16 - 70 mm ²	150 x 45 x 70	0.31	1	BTL3570

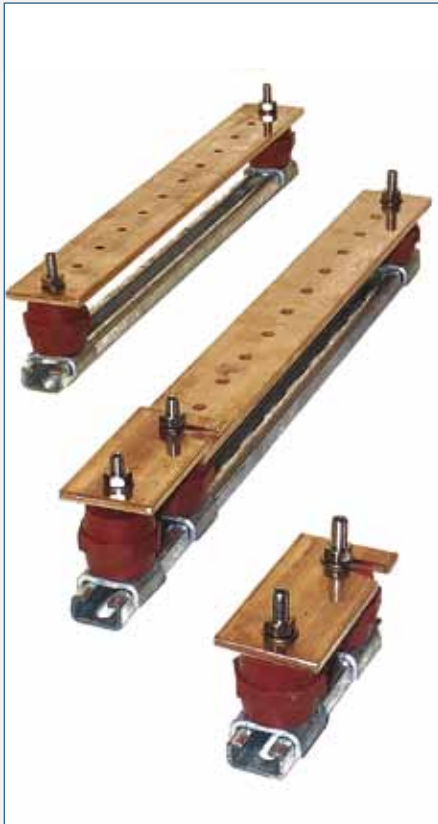

Equipotential bonding bars

Composed of a flat red copper conductor with a cross section of 50x5mm, perforated with a row of central holes of diameter 6.5mm, mounted on two low voltage insulators with fixing rail in hot-dip galvanized steel with slotted holes (9x25mm) for an easy set up. Stainless steel hardware.

Length (mm)	Number of free holes	(Kg)		Part Number
Version without disconnecting links:				
280	6	1.25	1	BET6
420	10	1.75	1	BET10
595	15	2.25	1	BET15
770	20	2.80	1	BET20
945	25	3.35	1	BET25
Version with disconnecting links:				
350	6	1.65	1	BETC6
490	10	2.15	1	BETC10
665	15	2.65	1	BETC15
840	20	3.20	1	BETC20
1015	25	3.75	1	BETC25
Disconnecting links only:				
105	-	0.70	1	BTC

Copper earthing plates

Manufactured with red copper with a cross section of 100x10mm with 20 holes of dia. 10.5mm for connections. As an option, the plates can be equipped with four insulators (H = 35mm) mounted with stainless steel hardware.

Designation	(Kg)		Part Number
Bare copper earthing plate, length 300mm	2.67	1	PT300-10
Copper earthing plate mounted on 4xM8 female to female insulators with a 35mm height	3.00	1	PTI300-10

On-demand: Holes of 8.5 dia. or 12.5mm, tinned or threaded plates.

On-demand equipotential bonding bars and earthing plates

We can manufacture, based on your drawings and specification, copper, tinned copper or stainless steel earthing plates.

In the same way, we also provide equipotential bonding bars mounted on insulators with or without the fixing rail.

Upon request, we can fully pre-equipped with stainless steel or copper alloy bolts.



Earthing collars				
Cross section (mm ²)	Tightening range on conduit (mm)	(Kg)		Part Number
2.5 mm ² - 16 mm ²	12-28 diameter	0.03	10	CMT1228
2.5 mm ² - 16 mm ²	18-48 diameter	0.06	10	CMT1848
2.5 mm ² - 16 mm ²	18-114 diameter	0.07	10	CMT18114
2.5 mm ² - 16 mm ²	18-165 diameter	0.08	10	CMT18165



Clamp for equipotential bonding on steel surface			
Body and M8 bolt in stainless steel			
Designation	(Kg)		Part Number
To connect a cable with a cross section from 4mm ² to 50mm ² max. on a steel surface with a thickness of 8mm max.	0.09	50	MS450I

Terminal clamp on steel structure



Terminal clamps on steel structure			
To connect conductor onto steel structure, tested according to IEC EN62561-1			
Designation	(Kg)		Part Number
Terminal clamp in stainless steel with clamping jaw (hole of 11mm) for steel structure from 5 to 19mm and conductors from 8 to 10mm in diameter.	0.30	25	GPH519I
Terminal clamp in stainless steel for steel structure from 5 to 19mm and conductor from 8 to 10mm in diameter..	0.25	25	GPH519I_8-10

Alternative terminal clamps available on demand.



Clamp for tape or round conductor to rebar with tall diameter			
Designation	(Kg)		Part Number
RU type clamp in galvanized steel for tape conductor of width 30 to 40 mm or round conductor of dia. 8 to 13mm max onto rebar of dia. 28 to 42mm max.	0.17	10 - 50	COSE-D10G



Clamp for tape conductor to rebar			
Designation	(Kg)		Part Number
Clamp in steel for tape conductor of width 30 to 40 max. onto rebar of dia. 6 to 25mm max.	0.126	25	RFB6-25/40
Clamp in galvanized steel for tape conductor of width 30 to 40 max. onto rebar of dia. 6 to 25mm max.	0.126	25	RFB6-25G/40G
Clamp in steel for tape conductor with a width of 30mm or for round conductor with a diameter of 10mm max onto rebar with a diameter from 6 to 20mm.	0.126	25	RFBP6-20/30

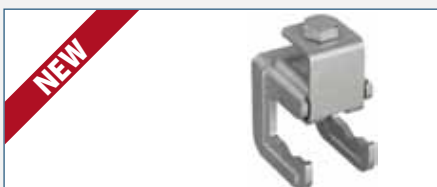



Stainless steel fixed earth terminal for concrete installation

To connect to rebars, according to IEC EN62561-1.

Designation	(Kg)		Part Number
Stainless steel 80mm dia. flask with an M12 central threading on 20mm then M10 on 20mm. The connecting stem has a 10mm dia with a length of 200m. Provided with its protection cap.	0,30	1 - 25	PTCM10-M12
Stainless steel 80mm dia. flask with an M16 central threading on 40mm. The connecting stem has a 10mm dia with a length of 200m. Provided with its protection capn	0.40	1	PTCM16



Fixed earth terminal clamps for cables or rebars

Designation	(Kg)		Part Number
Fixed earth terminal clamp (cross, tee or parallel) between the stem of the earthing terminal and rebar. Range capacity 8-10mm dia. / 8-10mm dia. Body in hot-dip galvanized steel, tightening done using stainless steel screw.	0.10	25	MVG8-10
Fixed earth terminal clamp (cross, tee or parallel) between the stem of the earth terminal and rebar. Range capacity 8-10mm dia. / 12-16mm dia. Body in hot-dip galvanized steel, tightening done using stainless steel screw.	0.12	25	MVG8-16
Fixed earth terminal clamp (cross, tee or parallel) between the stem of the earth terminal and rebar. Range capacity 8-16mm dia. / 12-15mm dia. Body in hot-dip galvanized steel, tightening done using stainless steel screw.	0.45	25	MVG8-25



Heavy duty square clamps

According to IEC EN62561-2

Material	Range (mm)			Bolts			Part Number
	round/round	round/flat	flat/flat				
2xM8 hot-dip galvanized steel bolts with threaded base plate model							
Hot-dip galvanized steel	D8-10/D8-10	D8-10/30	30/30	M8x25	0.14	50	RD30/8-10



Connection clamp for tape or round conductor to rebars

Designation	(Kg)		Part Number
Galvanized steel connection clamp for tape with a width of 30mm or cable with a diameter from 20 to 40mm to rebar with a diameter from 6 to 20mm.	0.307	25	RD40/10-40



Clamp for tape conductor to fixed earth terminal

Designation	(Kg)		Part Number
Stainless steel clamp for tape conductor with a width of 30mm on fixed earth terminal. Tightening done using 4xM8 stainless steel bolts. On demand : M10 central stud available.	0.25	1 - 10	SPCAI-M12



Clamp for round conductor or cable to fixed earth terminal

Designation	(Kg)		Part Number
Stainless steel clamp for round conductor with a dia. of 8-13mm max on fixed earth terminal. Tightening done using M8 stainless steel bolts and washer.	0.10	10	MVG8-10/PTCM

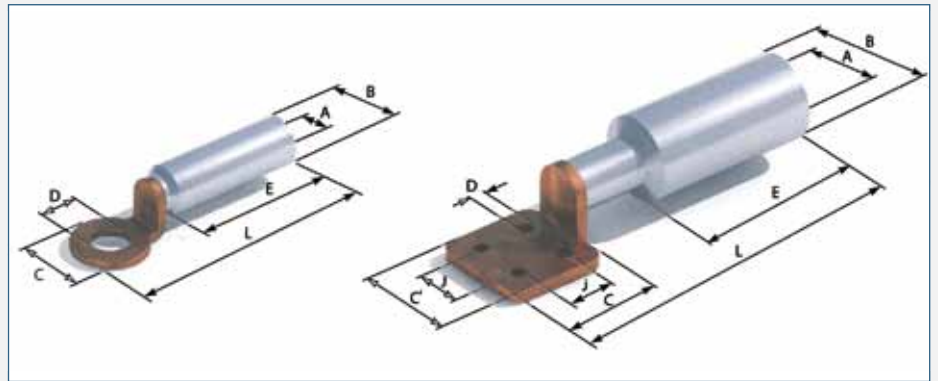

Copper/Aluminium compression lugs with long barrel connector

Manufactured according to NFC33-090-1 and according to EDF HN.68.S.90.

Material : barrel in aluminium (1050A) and terminals in copper (CuA1)

Welded by friction and tested one by one.

Cross section mm ²	A (mm)	B (mm)	E (mm)	L (mm)	C x C' (mm)	D (mm)	J (mm)	(Kg/100)		Part Number
16	5.5	16	47.5	79	20	10.5	-	4.50	3	COTALCU-16L
25	6.5				25	12.8	-	4.30	3	COTALCU-25L
35	8				-	4.10	3	COTALCU-35L		
50	9				-	7.00	3	COTALCU-50L		
70	11	20	47.5	86	25	12.8	-	6.70	3	COTALCU-70L
95	12.5	25	64	110	30	12.8	-	6.40	3	COTALCU-95L
120	13.7							12.60	3	COTALCU-120L
150	15.5							12.00	3	COTALCU-150L
185	17							21.50	3	COTALCU-185L
240	19.5	32	64	110	30	12.8	-	20.50	3	COTALCU-240L
300	23.3	40	100	142	36	16.5	-	34.50	3	COTALCU-300L
400	26							32.00	3	COTALCU-400L
500	29.1							63.00	3	COTALCU-500L
630	32.5							61.00	3	COTALCU-630L
800	37.5	47	101	200	60 x 60	4 x 9	30	156.00	3	COTALCU-800L
1000	42							146.00	3	COTALCU-1000L
1200	45.5							163.00	3	COTALCU-1200L

Copper/Aluminium compression lugs with short barrel connector for industrial networks facilities

Manufactured according to NFC63-061-B

Material : barrel in aluminium (1050A) and terminals in copper (CuA1)

Welded by friction and tested one by one. Reaming covered with grease.



Cross section mm ²	A (mm)	B (mm)	E (mm)	L (mm)	C (mm)	D (mm)	(Kg/100)		Part Number
35	8	16	34	70	20	10.5	3.00	3	COTALCU-35
50	9	16	34	70	20	10.5	3.00	3	COTALCU-50
70	11	20	34	70	20	10.5	4.00	3	COTALCU-70
95	12.5	20	34	70	20	10.5	3.90	3	COTALCU-95
120	13.7	20	34	70	20	10.5	3.80	3	COTALCU-120
150	15.5	27	38	81	24	10.5	12.90	3	COTALCU-150-10
150	15.5	27	38	81	24	12.8	12.80	3	COTALCU-150-12
185	17	27	40	90	24	10.5	14.20	3	COTALCU-185-10
185	17	27	40	90	24	12.8	14.00	3	COTALCU-185-12
240	19.5	27	40	90	30	10.5	15.00	3	COTALCU-240-10
240	19.5	27	40	90	30	12.8	14.80	3	COTALCU-240-12
300	22	32	42	92	30	10.5	17.40	3	COTALCU-300-10
300	22	32	42	92	30	14.5	17.00	3	COTALCU-300-14

Tinned copper tubular compression lugs

Manufactured in tinned copper, NFC20-130 compliant.



NFC20-130 compliant

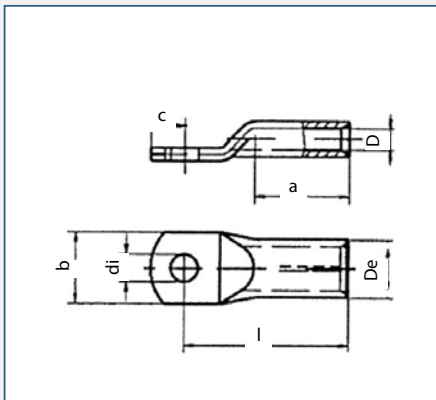

Cross Section	Di (mm)	D (mm)	De (mm)	b (mm)	a (mm)	c (mm)	l (mm)	(Kg/100)		Part Number
6 mm ²	5.3	3.3	5.5	13	11	6.5	24	0.35	100	COT6-5
	6.5	3.3	5.5	13	11	7.5	25	0.36	100	COT6-6
	8.5	3.3	5.5	13	11	10	28	0.42	100	COT6-8
	10.5	3.3	5.5	16	11	12	30	0.43	100	COT6-10
10 mm ²	6.5	4.2	6.8	12	12	6.50	24	0.49	100	COT10-6
	8.5	4.2	6.8	15	12	10	27	0.60	100	COT10-8
	10.5	4.2	6.8	16	12	12	29	0.72	100	COT10-10
	13	4.2	6.8	19	12	13	31	0.66	100	COT10-12
16 mm ²	6.5	5.5	8	12	14	6.25	27	0.68	100	COT16-6
	8.5	5.5	8	16	14	8.50	29	0.77	100	COT16-8
	10.5	5.5	8	16	14	10.50	31	0.79	100	COT16-10
	13	5.5	8	19	14	12	32	0.80	100	COT16-12
25 mm ²	6.5	6.6	9.5	13	15	6.25	30	1.05	100	COT25-6
	8.5	6.6	9.5	16	15	10	32	1.24	100	COT25-8
	10.5	6.6	9.5	17	15	12	34	1.33	100	COT25-10
	13	6.6	9.5	19	15	13	35	1.30	100	COT25-12
35 mm ²	6.5	7.9	11	15	17	7.50	32	1.33	100	COT35-6
	8.5	7.9	11	17	17	10	34	1.45	100	COT35-8
	10.5	7.9	11	17	17	12	37	1.60	100	COT35-10
	13	7.9	11	19	17	13	38	1.65	100	COT35-12
50 mm ²	8.5	9.2	12.5	18	19	10	37	1.95	100	COT50-8
	10.5	9.2	12.5	18	19	12	40	2.20	100	COT50-10
	13	9.2	12.5	19	19	13	41	2.31	100	COT50-12
	17	9.2	12.5	26	19	16	43	2.50	100	COT50-16
70 mm ²	8.5	11	15	21	21	10	41	3.18	100	COT70-8
	10.5	11	15	21	21	12	43	3.38	100	COT70-10
	13	11	15	22	21	13	46	3.58	100	COT70-12
	17	11	15	28	21	16	50	3.85	100	COT70-16
95 mm ²	8.5	13.1	17	25	25	10	46	4.25	50	COT95-8
	10.5	13.1	17	25	25	12	48	4.45	50	COT95-10
	13	13.1	17	25	25	13	50	4.65	50	COT95-12
	17	13.1	17	25	25	16	54	5.85	50	COT95-16
120 mm ²	10.5	14.5	19	28	26	12	52	5.90	50	COT120-10
	13	14.5	19	28	26	13	53	6.10	50	COT120-12
	17	14.5	19	28	26	16	56	6.60	50	COT120-16
150 mm ²	13	16.2	21	30	30	15	58	8.45	50	COT150-12
	17	16.2	21	30	30	16	59	8.30	50	COT150-16
	21	16.2	21	36	30	22	66	9.50	50	COT150-20
185 mm ²	13	18	23	34	32	16	65	11.20	50	COT185-12
	17	18	23	34	32	19	68	10.00	50	COT185-16
	21	18	23	40	32	21	70	11.40	50	COT185-20
240 mm ²	13	20.6	26	39	35	21.5	72	15.00	25	COT240-12
	17	20.6	26	39	35	21.5	72	14.60	25	COT240-16
	21	20.6	26	39	35	21.5	72	14.20	25	COT240-20
300 mm ²	13	23.1	28	41	44	16	80	15.25	20	COT300-12
	17	23.1	28	41	44	19	83	16.20	20	COT300-16
	21	23.1	28	41	44	21	85	16.95	20	COT300-20
400 mm ²	13	26.1	32	47	44	19	96	26.80	20	COT400-12
	17	26.1	32	47	44	19	96	25.60	20	COT400-16
	21	26.1	32	47	44	22	96	26.10	20	COT400-20

On-demand: compression lugs according to DIN46235.



Straight shape cable lugs

Body in copper alloy, U tightener in stainless steel (bronze on-demand)

Cross section (mm ²)	U size (mm)	(kg/100)		Part Number
16 to 50 mm ²	2 x M5	8.40	10 or 25	RD1050
10 to 70 mm ²	2 x M6	10.00	10 or 25	RD1070
25 to 120 mm ²	2 x M8	13.00	10 or 25	RD25120



Tee shape cable lugs

Body in copper alloy, U tightener in stainless steel (bronze on-demand)

Cross section (mm ²)	U size (mm)	(kg/100)		Part Number
16 to 50 mm ²	2 x M5	8.70	10 or 25	RT1050
10 to 70 mm ²	2 x M6	10.50	10 or 25	RT1070
25 to 150 mm ²	2 x M8	20.00	10 or 25	RT25120



Straight cable terminal lugs

Body in copper alloy, U tightener in stainless steel (bronze on-demand)

Cross section (mm ²)	Hole dia. (mm)	Terminal dia. (mm)	(kg/100)		Part Number
10 to 70 mm ²	9	24	7.20	10 or 25	CD1070-8
	11	24	7.20	10 or 25	CD1070-10
	13	24	7.20	10 or 25	CD1070-12
25 to 120 mm ²	13	30	13.20	10 or 25	CD25120-12



Tee shape lugs

Body in copper alloy, U tightener in stainless steel (bronze on-demand)

Cross section (mm ²)	Hole dia. (mm)	Terminal dia. (mm)	(kg/100)		Part Number
10 to 70 mm ²	9	24	8.00	10 or 25	CT1070-8
	11	24	8.00	10 or 25	CT1070-10
25 to 150 mm ²	13	30	18.00	10 or 25	CT25120-12



Flat angle bracket cable lugs

Body in copper alloy, U tightener in stainless steel (bronze on-demand)

Cross section (mm ²)	Hole dia. (mm)	Terminal dia. (mm)	(kg/100)		Part Number
10 to 70 mm ²	9	24	7.60	10 or 25	CE1070-8
25 to 120 mm ²	13	30	16.20	10 or 25	CE25120-12



Tinned copper C crimp connectors									
Cable nominal cross section	Combined cross section min-max (mm ²)		Min. capacity (mm ²)		Max. capacity (mm ²)		Scales (Kg/100)	Box icon	Part Number
			1	2	1	2			
16 mm ²	19	32	10	9	16	16	2	50	C16E
			16	2 x 1.5					
25 mm ²	35	50	25	10	25	25	2	50	C25E
25 mm ²	33	56	25	10	29	29	2.20	50	C25EGM
			27	6	35	16			
			30	2 x 1.5	30	16			
35 mm ²	53	70	30	25	35	35	3.70	50	C35E
			50	2 x 1.5	50	16			
50 mm ²	66	100	50	16	50	50	3.60	50	C50E
			63	2 x 1.5	70	30			
					75	25			
70 mm ²	85	140	70	25	70	70	9.20	25	C70E
75 mm ²	105	170	75	30	95	75	15.50	25	C75E
			70	35	95	70			
			90	16					
95 mm ²	150	190	75	75	95	95	14	25	C95E
120 mm ²	156	240	120	35	120	120	16	25	C120E
			150	6	150	50			
150 mm ²	225	300	150	75	150	150	12	10	C150E
185/95 mm ²	260	300	185	75	185	95	13	10	C185-95E
185 mm ²	210	370	115	95	185	185	25	10	C185E
			150	60	185	150			
240 mm ²	387	480	240	150	240	240	22	10	C240E



Copper C crimp connectors									
Cable nominal cross section	Combined cross section min-max (mm ²)		Min. capacity (mm ²)		Max. capacity (mm ²)		Scales (Kg/100)	Box icon	Part Number
			1	2	1	2			
16 mm ²	19	32	10	9	16	16	2	50	C16
			16	2 x 1.5					
25 mm ²	35	50	25	10	25	25	2	50	C25
25 mm ²	33	56	25	10	29	29	2.20	50	C25GM
			27	6	35	16			
			30	2 x 1.5	30	16			
35 mm ²	53	70	30	25	35	35	3.70	50	C35
			50	2 x 1.5	50	16			
50 mm ²	66	100	50	16	50	50	3.60	50	C50
			63	2 x 1.5	70	30			
					75	25			
70 mm ²	85	140	70	25	70	70	9.20	25	C70
75 mm ²	105	170	75	30	95	75	15.50	25	C75
			70	35	95	70			
			90	16					
95 mm ²	150	190	75	75	95	95	14	25	C95
120 mm ²	156	240	120	35	120	120	16	25	C120
			150	6	150	50			
150 mm ²	225	300	150	75	150	150	12	10	C150
185/95 mm ²	260	300	185	75	185	95	13	10	C185-95
185 mm ²	210	370	115	95	185	185	25	10	C185
			150	60	185	150			
240 mm ²	387	480	240	150	240	240	22	10	C240

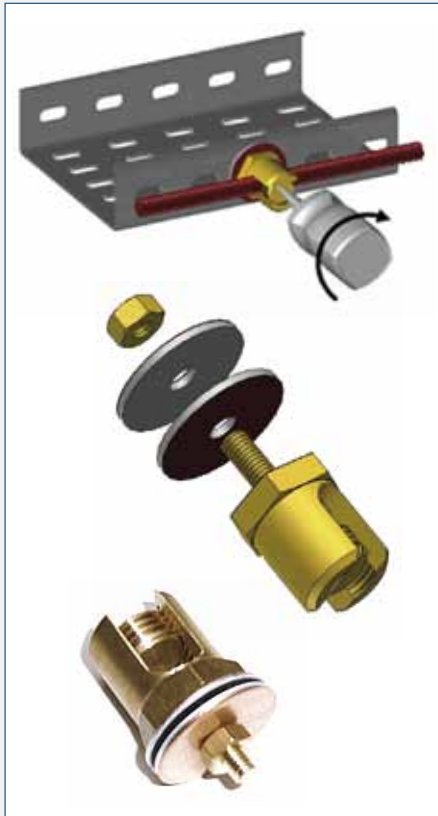

Fully assembled cable holders mounted with stud and two bi-metallic washers

Cross section (mm ²)	Conductor capacity	Stud size	Max thickness (mm)	(kg/100)		Part Number
25 mm ²	3-6 mm	M6	6	4.20	50	SEF25-6/2RBM
35 mm ²	4-8 mm		6	4.80	50	SEF35-6/2RBM
50 mm ²	7-10 mm		6	6.40	50	SEF50-6/2RBM
95 mm ²	8-12 mm		6	8.40	25	SEF95-6/2RBM
95 mm ²	8-12 mm		12	8.60	25	SEF95-6/2RBM/30
120 mm ²	10-14 mm		12	10.60	25	SEF120-6/2RBM
150 mm ²	10-16 mm		12	15.80	25	SEF150-6/2RBM
185 mm ²	12-18 mm		12	16.80	25	SEF185-6/2RBM
25 mm ²	3-6 mm	M7	12	4.30	50	SEF25-7/2RBM
35 mm ²	4-8 mm		12	4.90	50	SEF35-7/2RBM
50 mm ²	7-10 mm		12	6.50	50	SEF50-7/2RBM
95 mm ²	8-12 mm		12	8.50	25	SEF95-7/2RBM
120 mm ²	10-14 mm		12	10.70	25	SEF120-7/2RBM
150 mm ²	10-16 mm		12	16.00	25	SEF150-7/2RBM
185 mm ²	12-18 mm		12	17.00	25	SEF185-7/2RBM
120 mm ²	10-14 mm		M8	14	11.20	25
150 mm ²	12-16 mm	14		16.20	25	SEF150-8/2RBM
185 mm ²	12-18 mm	14		17.50	25	SEF185-8/2RBM
240 mm ²	16-20 mm	14		25.90	25	SEF240-8/2RBM
300 mm ²	22-23 mm	14		32.70	10	SEFB300-8/BM

Copper/aluminium bi-metallic washers

Hole diameter	Outer dia. x thickness (mm)	(kg/100)		Part Number
6.5 mm	20 x 1 mm	0.11	100	RBM6/20
6.5 mm	30 x 2 mm	0.46	100	RBM6
8.5 mm	30 x 2 mm	0.45	100	RBM8

Copper alloy stud and nut

Threading	L (mm)	a (mm)	b (mm)	(kg/100)		Part Number
M6	22	14	6	0.42	100	GOUJONM6/22-LAI
M6	30	18	8	0.60	100	GOUJONM6/30-LAI
M8	35	21	10	1.20	100	GOUJONM8/35-LAI
M6	nut			0.25	100	HUM6-LAI
M8	nut			0.55	100	HUM8-LAI



Copper alloy cable holder

Cross section (mm ²)	Conductor capacity (mm)	Base threading	(kg/100)		Part Number
25 mm ²	3-6 mm	M6	2.40	50	SEF25-6
35 mm ²	4-8 mm		3.10	50	SEF35-6
50 mm ²	7-10 mm		4.65	50	SEF50-6
95 mm ²	8-12 mm		6.71	25	SEF95-6
120 mm ²	10-14 mm		8.80	25	SEF120-6
150 mm ²	10-16 mm		14.00	25	SEF150-6
185 mm ²	12-18 mm		16.20	25	SEF185-6
25 mm ²	3-6 mm	M8	2.40	50	SEF25-8
35 mm ²	4-8 mm		3.10	50	SEF35-8
50 mm ²	7-10 mm		4.65	50	SEF50-8
95 mm ²	8-12 mm		6.71	25	SEF95-8
120 mm ²	10-14 mm		8.80	25	SEF120-8
150 mm ²	10-16 mm		14.00	25	SEF150-8
185 mm ²	12-18 mm		16.20	10	SEF185-8
240 mm ²	16-20 mm		16.20	10	SEF240-8
300 mm ²	22-23 mm		30.20	10	SEFB300-8



316 (A4) Stainless steel cable holders

Recommend on industrial plant, food and beverage, pharmaceutical, marine environment installation due to its resistance to corrosion.

Cross section (mm ²)	Conductor capacity (mm)	Base threading	(kg/100)		Part Number
16-35mm ²	3-8 mm	M6	3,10	50	SEF35-6-I316
50mm ²	7-10 mm		4,90	50	SEF50-6-I316
95mm ²	8-12mm		6,30	25	SEF95-6-I316



Aluminium connector for round conductors

Designation	(kg/100)		Part Number
Connector with galvanized steel body and aluminium ring for conductor from 6 to 10mm in diameter.	0.59	50	KS610-AL

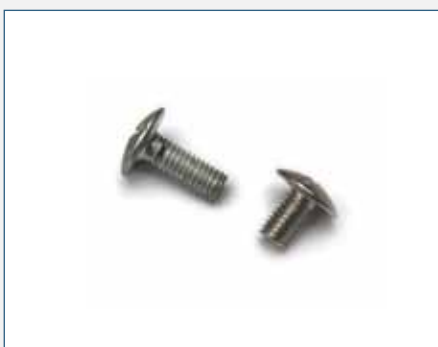

Stainless steel stove screw

Threading	L (mm)	(kg/100)		Part Number
M6	10	0.45	100	TPM6x10-A2
	12	0.48	100	TPM6x12-A2
	16	0.53	100	TPM6x16-A2
	20	0.42	100	TPM6x20-A2
M8	16	1.10	100	TPM8x16-A2

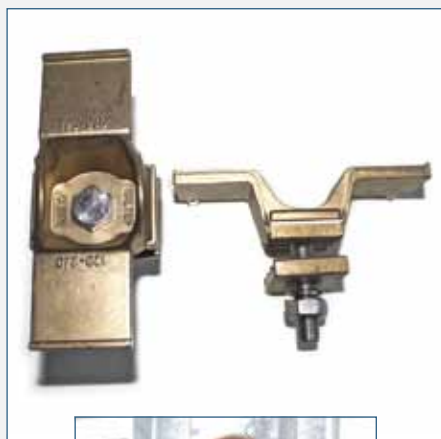

Winged earth clamps

Body in copper alloy, resistant to corrosion.
Stainless steel hardware.

Min. Max. cable capacity (mm ²)	Bolt size	(Kg)		Part Number
2 x (50 to 120 mm ²)	M12 x 60	0.60	20	CLPAR50-120
2 x (120 to 240 mm ²)	M12 x 70	0.80	20	CLPAR120-240
2 x (120 to 300 mm ²)	M16 X 80	0.91	10	CLPAR185-300

On demand : Tinned version

Double winged earth clamps

Body in copper alloy, resistant to corrosion.
Stainless steel hardware.

Min. Max. cable capacity (mm ²)	Bolt size	(Kg)		Part Number
4 x (50 to 120 mm ²)	M12 x 80	0.60	20	2CLPAR50-120
4 x (120 to 240 mm ²)	M12 x 90	0.80	15	2CLPAR120-240
4x (120 to 300 mm ²)	M16 X 100	1.05	10	2CLPAR185-300

On demand : Tinned version

Copper / Aluminium bi-metallic plates

Hole diameter	Dimensions X thickness (mm)	(Kg/100)		Part Number
10.5 mm	55 x 40 x 1 mm	0.80	100	PBM10
12.5 mm	55 x 40 x 1 mm	0.77	100	PBM12
14.5 mm	55 x 40 x 1 mm	0.75	100	PBM14
16.5 mm	55 x 40 x 1 mm	0.70	100	PBM16

Note: - Insert a bi-metallic plate as well as a washer when mounting our earth clamps series on galvanized steel surface to prevent from galvanic corrosion.

- Please refer to our earth clamp series with copper alloy bolts approved by the French national utility company (RTE CNER), refer to page 39 to 43.



Earth clamp

Body in copper alloy, resistant to corrosion.
Stainless steel hardware.

Min. Max. cable capacity (mm ²)	Screw size	(Kg)		Part Number
2 x (16 to 70 mm ²)	M10 x 40	0.13	25	CPAR50
2 x (50 to 120 mm ²)	M12 x 60	0.25	25	CPAR50-120
2 x (120 to 240 mm ²)	M12 x 70	0.35	25	CPAR120-240
2 x (120 to 300 mm ²)	M16 X 80	0.43	10	CPAR185-300

On demand : Tinned version



Double earth clamp

Body in copper alloy, resistant to corrosion.
Stainless steel hardware.

Min. Max. cable capacity (mm ²)	Screw size	(Kg)		Part Number
4 x (50 to 120mm ²)	M12 x 80	0.34	10	2CPAR50-120
4 x (120 to 240mm ²)	M12 x 90	0.50	10	2CPAR120-240
4 x (120 to 300 mm ²)	M16 X 100	0.60	10	2CPAR185-300

On demand : Tinned version



Copper/aluminium bi-metallic washers

Hole diameter	Dimensions X thickness (mm)	(Kg/100)		Part Number
6.5 mm	30 x 2 mm	0.46	100	RBM6
8.5 mm	30 x 2 mm	0.45	100	RBM8
10.5 mm	30 x 2 mm	0.45	100	RBM10
13 mm	30 x 2 mm	0.45	100	RBM12
14.5 mm	30 x 2 mm	0.45	100	RBM14
16.5 mm	30 x 2 mm	0.45	100	RBM16

Note: - Insert a bi-metallic plate as well as a washer when mounting our earth clamps series on galvanized steel surface to prevent from galvanic corrosion.

- Please refer to our earth clamp series with copper alloy bolts approved by the French national utility company (RTE CNER), refer to page 39 to 43.

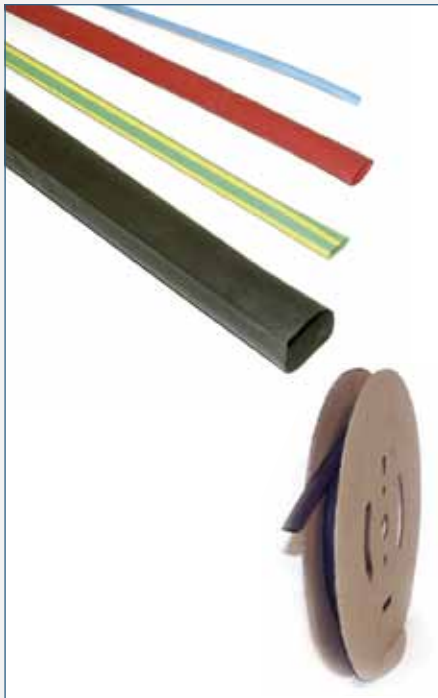

Small duty heat shrink tube

Material: thin wall in polyolefin, standard black color (on-demand color, please refer to color code)
 Shrink ratio: 2/1
 Shrink temperature: > 100°C
 Operating temperature : -50°C to +120°C
 Di-electrical resistance: > 20kV/mm
 UV resistant

Pre-shrink diameter (mm)	Post-shrink diameter (mm)	Post shrink wall thickness (mm)		Part Number
3.2	1.6	0.51	(*)	GPF-1/8
4.8	2.4	0.51	(*)	GPF-3/16
6.4	3.2	0.64	(*)	GPF-1/4
9.5	4.8	0.64	(*)	GPF-3/8
12.7	6.4	0.64	(*)	GPF-1/2
19.1	9.5	0.76	(*)	GPF-3/4
25.4	12.7	0.89	(*)	GPF-1
31.8	15.9	0.89	(*)	GPF-1-1/4
38.1	19.1	1.02	(*)	GPF-1-1/2
51	25.4	1.14	(*)	GPF-2
76	38	1.27	(*)	GPF-3

(*) : Other colors available with a length of 1m, coils also available (to be confirmed upon order)
 Color code to be added to the product part number: VJ: Green/Yellow, R: Red, M: Brown, BLC: White, O: Orange



Waterproof regular dual wall duty heat shrink tube

Material: regular wall in polyolefin, standard black color
 Shrink ratio: 3/1
 Shrink temperature: > 110°C
 Operating temperature : -55°C to +110°C
 Di-electrical resistance: > 15kV/mm
 UV resistant, halogen free
 Available in length of 1m

Pre-shrink diameter (mm)	Post-shrink diameter (mm)	Post shrink wall thickness (mm)		Part Number
8	2	1.3	5	GPMA8/2
12	3	1.4	5	GPMA12/3
22	6	2	5	GPMA22/6
34	7	2.6	5	GPMA34/7
40	12	2.6	5	GPMA40/12
56	16	2.7	5	GPMA56/16
75	22	3	5	GPMA75/22
95	26	3.2	5	GPMA95/26
120	34	3.3	5	GPMA120/34



Waterproof heavy dual wall duty heat shrink tube

Material: regular wall in polyolefin, standard black color
 Shrink ratio: 3/1
 Shrink temperature: > 110°C
 Operating temperature : -55°C to +110°C
 Di-electrical resistance: > 15kV/mm
 UV resistant, halogen free
 Available in length of 1m

Pre-shrink diameter (mm)	Post-shrink diameter (mm)	Post shrink wall thickness (mm)		Part Number
12	3	2.5	5	GPEA12/3
19	6	2.7	5	GPEA19/6
30	8	4	5	GPEA30/8
45	12	4	5	GPEA45/12
52	12	4.1	5	GPEA52/12
72	20	4.2	5	GPEA72/20
92	26	4.3	5	GPEA92/26
120	34	4.6	5	GPEA120/34



Heavy duty bar holder

Body in copper alloy, high mechanical resistant and resistant to corrosion. Provided fully mounted with stainless steel screws.

Max. width L (mm)	Max. thickness (mm)	Treading T	Screw size	(Kg)		Part Number
30-32	8	M8	2 x M6	0.11	50	SL-30
40	10	M8	2 x M6	0.11	50	SL-40
50	10	M10	2 x M8	0.21	25	SL-50
60	10	M10	2 x M8	0.34	25	SL-60
70	12	M10	2 x M8	0.34	10	SL-70
80	12	M10	2 x M8	0.45	10	SL-80

Heavy duty bar holder accessories

Designation	Dimensions			(Kg)		Part Number
	L (mm)	T	D (mm)			
Dowel screw	50	M8		1.00	50	PV-M8
Plastic screw anchor	44		10	0.12	100	C10
Dowel screw	60	M10		1.30	50	PV-M10
Plastic screw anchor	57		12	0.14	25	C12



Parallel cable clamps

Body in tinned copper alloy, zinc plated hardware.

Min. Max. cable capacity (mm ²)	Bolts	(Kg)		Part Number
4 to 29 mm ²	M6	0.027	50	RAG430
10 to 50 mm ²	M6	0.04	50	RAG1050
10 to 50 mm ²	2 x M6	0.07	25	RAG10502
16 to 95 mm ²	2 x M6	0.095	25	RAG16952
25 to 150 mm ²	2 x M8	0.198	10	RAG25150



Parallel cable clamps with stainless steel hardware

Body in tinned copper alloy, stainless steel hardware.

Min. Max. cable capacity (mm ²)	Screw	(Kg)		Part Number
4 to 29 mm ²	M6	0.027	50	RAG430I
10 to 50 mm ²	M6	0.04	50	RAG1050I



Threaded hexagonal A2 stainless steel bolts (DIN933 ISO4017)

Threading	Length (mm)	Width (mm)	Kg/100		Part Number
M6	12	10	0.43	200	THM6x12-A2
	16		0.55	200	THM6x16-A2
	20		0.61	200	THM6x20-A2
	25		0.66	200	THM6x25-A2
	30		0.76	200	THM6x30-A2
M8	16	13	1.08	200	THM8x16-A2
	20		1.23	200	THM8x20-A2
	25		1.36	200	THM8x25-A2
	30		1.51	200	THM8x30-A2
	40		1.85	200	THM8x40-A2
M10	20	17	2.17	100	THM10x20-A2
	25		2.43	100	THM10x25-A2
	30		2.68	100	THM10x30-A2
	40		3.12	100	THM10x40-A2
M12	40	19	4.38	100	THM12x40-A2
	50		5.22	50	THM12x50-A2
	60		6.06	50	THM12x60-A2
	70		6.90	50	THM12x70-A2
	80		7.60	50	THM12x80-A2

A4 Stainless steel and alternatives dimensions available on-demand.



A2 Stainless steel threaded rods (DIN975)

Threading	Length (mm)	Kg/100		Part Number
M6	1000	0.17	5	TFM6-A2
M8	1000	0.31	5	TFM8-A2
M10	1000	0.51	5	TFM10-A2
M12	1000	0.70	1	TFM12-A2
M16	1000	1.33	1	TFM16-A2



A2 stainless steel nuts (DIN934 ISO4032)

Threading	Height (mm)	Width (mm)	Kg/100		Part Number
M6	5	10	0.22	200	HUM6-A2
M8	6.5	13	0.46	200	HUM8-A2
M10	8	17	1.06	100	HUM10-A2
M12	10	19	1.56	100	HUM12-A2
M16	12	24	3.05	50	HUM16-A2



A2 stainless steel washers (DIN125 ISO7089)

Hole diameter (mm)	Outer diameter (mm)	Thickness (mm)	Kg/100		Part Number
6.4	12	1.6	0.11	200	RDEL6-A2
8.4	16	1.6	0.2	200	RDEL8-A2
10.5	20	2	0.41	100	RDEL10-A2
13	24	2.5	0.80	100	RDEL12-A2
17	30	3	1.25	100	RDEL16-A2



A2 stainless steel grower washers (DIN127B)

Hole diameter (mm)	Outer diameter (mm)	Thickness (mm)	Kg/100		Part Number
6.1	11.8	1.6	0.09	200	RDELW6-A2
8.1	14.8	2	0.15	200	RDELW8-A2
10.2	18.1	2.2	0.25	100	RDELW10-A2
12.2	21.1	2.5	0.37	100	RDELW12-A2
16.2	27.4	3.5	0.75	100	RDELW16-A2



Copper alloy screw with hexagon head (DIN933 ISO4017)

Threading	Length (mm)	Width (mm)	Kg/100		Part Number
M6	12	10	0.52	200	THM6x12-LAI
	16		0.60	200	THM6x16-LAI
	20		0.65	200	THM6x20-LAI
	25		0.73	200	THM6x25-LAI
	30		0.82	200	THM6x30-LAI
M8	20	13	1.26	200	THM8x20-LAI
	25		1.47	200	THM8x25-LAI
	30		1.62	200	THM8x30-LAI
M10	30	17	2.80	50	THM10x30-LAI
	40		3.30	50	THM10x40-LAI
M12	40	19	4.90	50	THM12x40-LAI
	60		6.50	50	THM12x60-LAI

Other dimension available on-demand



Copper alloy nuts (DIN934 and ISO4032)

Threading	Height (mm)	Width (mm)	Kg/100		Part Number
M6	5	10	0.25	200	HUM6-LAI
M8	6.5	13	0.55	200	HUM8-LAI
M10	8	17	1.2	100	HUM10-LAI
M12	10	19	1.8	100	HUM12-LAI



Copper alloy washers (DIN125 ISO7089)

Hole diameter (mm)	Outer diameter (mm)	Thickness (mm)	Kg/100		Part Number
6.4	12	1.6	0.12	200	RDEL6-LAI
8.4	16	1.6	0.25	200	RDEL8-LAI
10.5	20	2	0.48	100	RDEL10-LAI
13	24	2.5	0.98	100	RDEL12-LAI

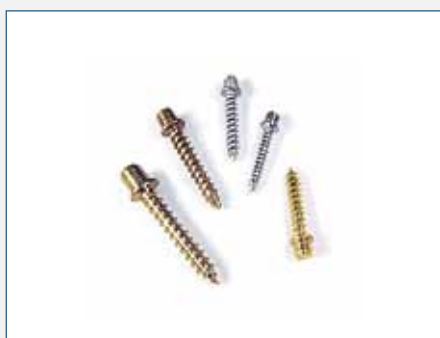

Dowel screws

Material	Head size x height (mm)	Total length (mm)	Kg/100		Part Number
Galvanized steel	M6 x 6	38	0.42	50	PV-M6
Galvanized steel	M7 x 7	38	0.59	50	PV-M7
Copper alloy	M7 x 7	38	0.59	50	PV-M7LAI
Galvanized steel	M8 x 8	48	1.00	50	PV-M8
Galvanized steel	M10 x 10	57	1.60	50	PV-M10

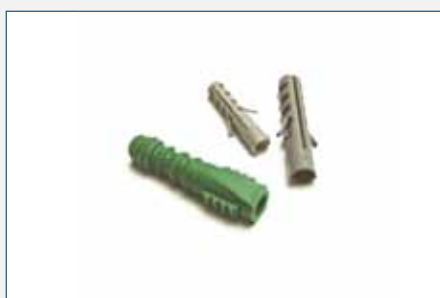

Plastic screws anchors

Diameter (mm)	Length (mm)	Kg/100		Part Number
6	30	0.10	100	C6
8	40	0.17	100	C8
10	44	0.26	50	C10
12	57	0.48	25	C12



Zip ties
 Material: polyamide 12 black
 Operating temperature: -40°C to +60°C (peak at 120°C)
 Di-electrical strenght: 28kV/mm
 Flame resistance: UL 94 class HB
 Conform to EDF HN 33/S/62 specifications

Width (mm)	Length (mm)	Max. tightening dia.(mm)	Strength resistance (daN)		Part Number
6	120	22	25	100	CP6-120
6	180	42	25	100	CP6-180
6	280	62	25	100	CP6-280
6	360	92	25	100	CP6-360
9	120	22	35	100	CP9-120
9	180	42	35	100	CP9-180
9	265	62	51	100	CP9-265
9	360	92	51	100	CP9-360
9	510	140	55	100	CP9-510
9	760	220	55	100	CP9-760



Push-in zip ties mount
 For zip ties

Diameter (mm)	Length (mm)	Way dimension			Part Number
		Thickness (mm)	Width (mm)		
10 --> Drill at 8	37	6.5	9.2	100	PFC9-6
10 --> Drill at 8	37	13	9.2	100	PFC9-13



Stainless steel zip ties
 Operating temperature: -40°C to +540°C
 Material : 302/304 stainless steel

Width (mm)	Length (mm)	Max. tightening dia.(mm)	Strength resistance (daN)		Part Number
4.6	201	51	45	100	CI4-201
4.6	360	102	45	100	CI4-360
4.6	520	152	45	100	CI4-520
4.6	679	203	45	100	CI4-680
4.6	838	254	45	100	CI4-840
7.9	201	51	113	100	CI7-201
7.9	360	102	113	100	CI7-360
7.9	520	152	113	100	CI7-520
7.9	679	203	113	100	CI7-680
7.9	838	254	113	100	CI7-840
7.9	1016	305	113	50	CI7-1010



Gripped tie gun for zip ties installation

To be used with zip ties from 4.6mm and 7.9mm	0.80	1	CT3
---	------	---	-----



Stainless steel ribbon ties AISI201 stainless steel, approved by EDF Coils of 50m			
Designation	Kg		Part Number
10x0.4mm stainless steel ribbon ties	1.80	50 m	F104
10x0.7mm stainless steel ribbon ties	3.00	50 m	F107
20x0.4mm stainless steel ribbon ties	3,50	50 m	F204
20x0.7mm stainless steel ribbon ties	5,90	50 m	F207



Staples			
Designation	Kg/100		Part Number
Stainless steel staples for 10mm ribbon ties	0.36	100	A100
Stainless steel staples for 20mm ribbon ties	0.60	100	A200



Gripped tie gun			
Designation	Kg		Part Number
Gripped tie gun for 10 or 20mm ribbon ties	1.40	1	OPL



Fixing clamp for ribbon ties			
Designation	Kg/100		Part Number
Stainless fixing clamp for 10mm ribbon ties. Slot of 15x2.2mm to pass the ribbon. Provided with stainless steel M8 screw.	2.40	50	EC18

Power Substation Hardware



Maltep's products approved by the French national utility company (RTE CNER) and in full compliance with DTP S404 and DTP 455 RTE CNER specifications.

Overview of the mechanical and electrical tests performed on our products according to RTE CNER specifications done by third party laboratories



Static traction test done on a MALTEP MCL185 coupler mounted on 185mm² bare copper cables and put under a stress load of 1750daN during 1 minute : not slip were observe on the sample.

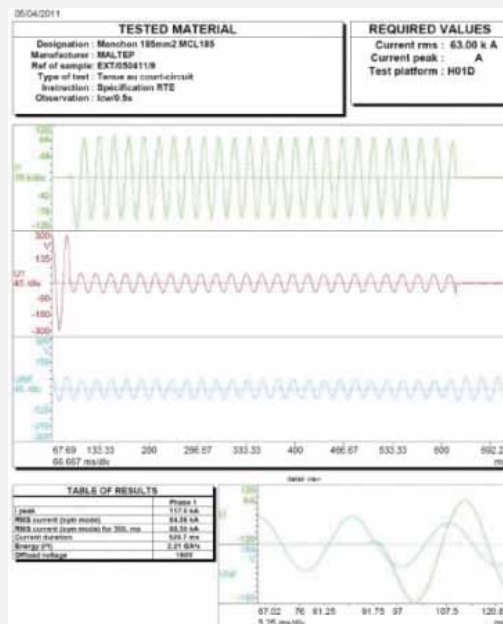

A 63kA short circuit test performed on MALTEP MCL185 coupler and tubular compression lug with a 185mm² bare copper cable during 0.5 sec.



A Maltep MCL serie coupler state after a short circuit test.



A 40kA short-circuit test performed on a flexible 150mm² MALTEP tinned copper earth braid from our TME product series during 1 sec.



A 30kA short-circuit test performed on a MALTEP earth clamp from our CPAR product series with a 116mm² bare copper cable during 1 sec.

Maltep's products approved by the French national utility company (RTE CNER) and in full compliance with DTP S404 and DTP 455 RTE CNER specifications.



Earth clamp							
RTE CNER marks	RTE CNER Reference	Cables cross section (mm ²)	Bolt	Recommended torque (Nm)	Short circuit intensity withstand (A)	Weight (kg)	MALTEP Part Number
A1	STN-75/116	50-120 (70, 75, 116)	M12	36	30kA/1s	0,27	CPAR50-120L
A2	STN-146	150 (146)	M14	55	40kA/1s	0,28	CPAR150L
A3	STN-182	185 (182)	M16	70	63kA/0,5s	0,47	CPAR185L



Double earth clamp							
RTE CNER marks	RTE CNER Reference	Cables cross section (mm ²)	Bolt	Recommended torque (Nm)	Short circuit intensity withstand (A)	Weight (kg)	MALTEP Part Number
C1	STND-75/116	50-120 (70, 75, 116)	M12	36	30kA/1s	0,36	2CPAR50-120L
C2	STND-146	150 (146)	M14	55	40kA/1s	0,37	2CPAR150L
C3	STND-182	185 (182)	M16	70	63kA/0,5s	0,64	2CPAR185L



Winged earth clamp							
RTE CNER marks	RTE CNER Reference	Cables cross section (mm ²)	Bolt	Recommended torque (Nm)	Short circuit intensity withstand (A)	Weight (kg)	MALTEP Part Number
B2	STA-2/75-116	50-120 (70, 75, 116)	M12	36	30kA/1s	0,62	CLPAR50-120L
B3	STA-2/146	150 (146)	M14	55	40kA/1s	0,63	CLPAR150L
B4	STA-2/182	185 (182)	M16	70	63kA/0,5s	0,90	CLPAR185L



Double winged earth clamp							
Repère RTE CNER	RTE CNER Reference	Cables cross section (mm ²)	Bolt	Recommended torque (Nm)	Short circuit intensity withstand (A)	Weight (kg)	MALTEP Part Number
D2	STDA-2/75-116	50-120 (70, 75, 116)	M12	36	30kA/1s	0,71	2CLPAR50-120L
D3	STDA-2/146	150 (146)	M14	55	40kA/1s	0,72	2CLPAR150L
D4	STDA-2/182	185 (182)	M16	70	63kA/0,5s	1,08	2CLPAR185L

Use a Copper/Aluminium bi-metallic plate and washer when the earth clamp is mounted on a galvanized steel surface to prevent from galvanic corrosion to occur.

Maltep's products approved by the French national utility company (RTE CNER) and in full compliance with DTP S404 and DTP 455 RTE CNER specifications.

Straight compression lugs with long barrel for earth cables

RTE CNER marks	RTE CNER Reference	Cables cross section (mm ²)	Hole dia. (mm)	width X thickness (mm)	Short circuit intensity withstand (A)	Weight (kg)	MALTEP Part Number
F1	CDCT75 10	70, 75	10.5	24 x 4.5	20kA/1s	0.06	COTD75-10
	CDCT75 12	70, 75	13		20kA/1s	0.06	COTD75-12
F2	CDCT120 10	120 (116)	10.5	32 x 5	30kA/1s	0.11	COTD120-10
	CDCT120 12	120 (116)	13		30kA/1s	0.11	COTD120-12
F3	CDCT146 12	150 (146)	13	34 x 6	40kA/1s	0.16	COTD150-12
	CDCT146 16	150 (146)	17		40kA/1s	0.16	COTD150-16
F4	CDCT182 14	185 (182)	15	37 x 6	63kA/0.5s	0.19	COTD185-14
	CDCT182 16	185 (182)	17		63kA/0.5s	0.19	COTD185-16



Copper compression sleeves

RTE CNER marks	RTE CNER Reference	Cables cross section (mm ²)	Short circuit intensity withstand (A)	Weight (kg)	MALTEP Part Number
M1	MCL75	70, 75	20kA/1s	0.07	MCL75
M2	MCL120	120 (116)	30kA/1s	0.15	MCL120
M3	MCL150	150 (146)	40kA/1s	0.20	MCL150
M4	MCL185	185 (182)	63kA/0.5s	0.23	MCL185



Cable holders

RTE CNER marks	RTE CNER Reference	Cables cross section (mm ²)	Width capacity (mm)	Stud Size	Weight (kg)	MALTEP Part Number
L1	SF12.7+BM	70, 75	12	M7	0.09	SEF95-7/2RBM
L2	SF14.7+BM	120 (116)	14	M7	0.11	SEF120-7/2RBM
L3	SF16.7+BM	150 (146)	16	M7	0.16	SEF150-7/2RBM
L4	SF20.7+BM	185 (182)	18	M7	0.19	SEF185-7/2RBM



The cable holder is provided with a middle stud, nut and two 30mm dia. bi-metallic washers in copper/aluminium. The remaining length provided by the stud allows direct mounting on surface with a thickness of 12mm max.

Maltep's products approved by the French national utility company (RTE CNER) and in full compliance with DTP S404 and DTP 455 RTE CNER specifications.



Flexible tinned copper earth braids								
RTE CNER marks	RTE CNER Reference	Earth braid Cross section (mm ²)	Hole diam. (mm)	Length between hole axes (mm)	Connector dimensions LxWxThick (mm)	Short circuit intensity withstand (A)	Weight (kg)	MALTEP Part Number
S1	TME75300-13	75	13	300	31x30x7	20kA/1s	0.26	TME75300-12
	TME75500-13			500			0.39	TME75500-12
	TME75700-13			700			0.55	TME75700-12
	TME75900-13			900			0.70	TME75900-12
S2	TME120300-13	120	13	300	40x40x8	30kA/1s	0.44	TME120300-12
	TME120500-13			500			0.68	TME120500-12
	TME120700-13			700			0.91	TME120700-12
	TME120900-13			900			1.16	TME120900-12
S3	TME150300-13	150	13	300	47x50x7	40kA/1s	0.62	TME150300-12
	TME150500-13			500			0.92	TME150500-12
	TME150700-13			700			1.14	TME150700-12
	TME150900-13			900			1.44	TME150900-12
S4	TME185300-13	185	13	300	47x50x9	63kA/0,5s	0.72	TME185300-12
	TME185500-13			500			1.10	TME185500-12
	TME185700-13			700			1.47	TME185700-12
	TME185900-13			900			1.96	TME185900-12



Copper or tinned copper C crimp connectors for earthing circuits							
RTE CNER marks	RTE CNER Reference	Cables cross section (mm ²)	Short circuit Intensity withstand		Weight (kg)	MALTEP Part Number	
			through (A)	derived		Copper	Tinned copper
		70,75 - 70,75	20kA/1s	20kA/1s	0.15	C75	C75E
J1	RDCT-75/75	75	20kA/1s	20kA/1s	0.14	C95	C95E
J2	RDCT-116/75	120 (116) - 70, 75	30kA/1s	20kA/1s	0.16	C120	C120E
J3	RDCT-116/116	120 (116) - 120 (116)	30kA/1s	30kA/1s	0.16	C120	C120E
J4	RDCT-146/75	150 (146) - 70, 75	40kA/1s	20kA/1s	0.12	C150	C150E
J5	RDCT-146/146	150 (146) - 150 (146)	40kA/1s	40kA/1s	0.12	C150	C150E
J6	RDCT-182/75	185 (182) - 70, 75	63kA/0.5s	20kA/1s	0.13	C185-95	C185-95E
J7	RDCT-182/182	185 (182) - 185 (182)	63kA/0.5s	63kA/0.5s	0.25	C185	C185E



Copper/Aluminium bi-metallic plate and washer for earth clamp					
RTE CNER marks	RTE CNER Reference	Dimensions (mm)	Hole diam. (mm)	Weight per hundred pces (Kg)	MALTEP Part Number
E1	PBST1/12.14	55 x 40 x 1	14.3	0.75	PBM14
E3	PBST1/16	55 x 40 x 1	16.5	0.70	PBM16
E2	PBST2/12.14	Dia.30 x 2	14.3	0.40	RBM14
E4	PBST2/16	Dia.30 x 2	16.5	0.36	RBM16

Lightning Protection



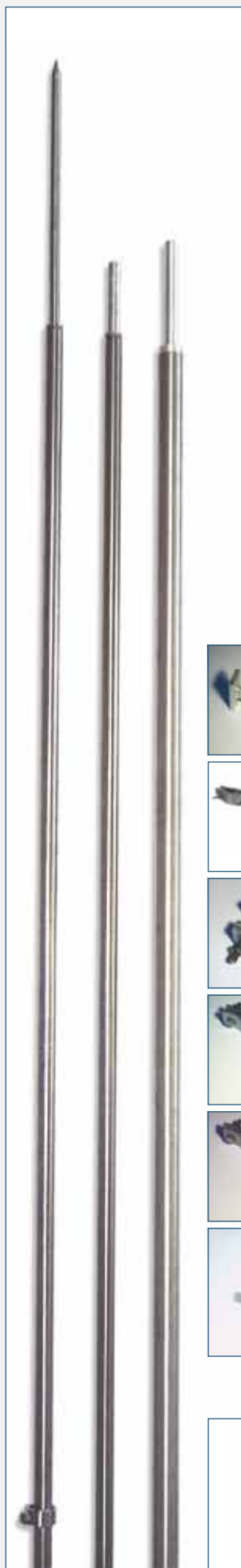

Lightning rods

Designation	Kg		Part Number
Stainless steel lightning rod, length of 1.50m , provided with a stainless steel collar to connect it with 30x2mm tape conductor	2.50	1	PTS-150/30I
Stainless steel lightning rod, length of 2m , provided with a stainless steel collar to connect it with 30x2mm tape conductor	3.20	1	PTS-200/30I
Stainless steel lightning rod, length of 2.5m , provided with a stainless steel collar to connect it with 30x2mm tape conductor	3.90	1	PTS-250/30I
Stainless steel mast extension N°1, 30mm dia., Length of 2m	3	1	MR-1I
Stainless steel mast extension N°2, 42mm dia., Length of 2m	4.7	1	MR-2I
Stainless steel mast extension N°3, 42mm dia., Length of 2m	5	1	MR-3I
Hot-dip galvanized steel bracket with a wall offset of 220mm. Tightening range from 27 to 55mm in dia. Stainless steel hardware.	1.45	1	PFD
Hot-dip galvanized steel lateral bracket. Tightening range from 27 to 55mm in dia. Stainless steel hardware.	1.45	1	CFD
Stainless steel cross bracket. Tightening range from 27 to 55mm in dia. Stainless steel hardware.	1.40	1	CDC
Stainless steel bracket for mounting on 114mm diameter pipe. Lightning rod diameter range from 27 to 55 mm. Stainless steel hardware.	1.20	1	PLD114
Stainless steel bracket for mounting on 114mm diameter pipe. Lightning rod diameter range from 18 to 20 mm. Stainless steel hardware.	1.20	1	PLD114/18
Stainless steel clamp for connection of 30mm flat conductor on lightning rod or mast.	0.30	1	COS2E

Clamp for lightning rod

Designation	Kg		Part Number
Stainless steel clamp for a 30mm diameter lightning rod with 30x2mm down conductor.	0.14	1	COSP-250/30I



Lightning rod base			
Designation	Kg		Part Number
Lightning rod base to mount a lightning rod onto steel surfaces. Threaded base in M6x70mm Stainless steel body and hardware	0.85	1	EMBM16I



Free standing air terminal support			
Designation	Kg		Part Number
Designed to mount lightning rod on roof top. Hot-dip galvanized steel body with stainless steel hardware..	7	1	TPM



Lightning air terminal and mounting accessories According to IEC EN62561-2			
Designation	Kg		Part Number
Stainless steel air terminal, threaded base in M10 with a dia. of 18mm, length of 300mm.	0.56	1	PCA318I
Stainless steel air terminal, threaded base in M10 with a dia. of 18mm, length of 500mm.	0.94	1	PCA518I
Stainless steel air terminal, threaded base in M10 with a dia. of 18mm, length of 1000mm.	1.90	1	PCA1018I
Stainless steel threaded M10 rod with waterproof washers and nuts.	0.08	1	TPCIx
Stainless steel straight angle plate with M10 bolts.	0.20	1	PEPIx
Stainless steel squared plate with M10 central stud and bolts.	0.08	1	PPCIx
Stainless steel square clamp for ribbon up to 30mm width. M10 central stud for mounting onto the air terminal.	0.25	1	SPCAI-M10

Heavy duty square clamps

According to IEC EN62561-2

Material	Range (mm)			Bolts			Part Number
	round/round	round/flat	flat/flat				
4xM6 stainless steel bolts model							
Tinned copper	-		30 / 30	M8x25	0,31	50	RCR302
Stainless steel	-	D8-12 / 30	30 / 30	M8x25	0.23	50	RCI302
Stainless steel	-	D8-12/30	30/30	M8x40	0.30	10	RCI302/40
Stainless steel	-	-	30 / 30	M8x25	0.23	50	RCIP302
Stainless steel	D8-12/D8-12	D8-12/30	30 / 30	M8x25	0.24	50	RCI8302
Hot-dip galvanized steel	-	-	30/30	M8x25	0.24	50	RCRG302



Stainless steel clamp for round conductor or earth point

Designation	 (Kg)		Part Number
Stainless steel clamp to connect in cross or parallel two round conductors with a diameter from 8 to 10mm.	0.95	25	MVI8-10

Copper clamp for round conductor or earth point

Designation	 (Kg)		Part Number
Copper clamp to connect in cross or parallel two round conductors with a diameter from 8 to 10mm.	0.95	25	MVCU8-10

Find out more about our 30x2mm tinned copper tape and our whole down conductors product range according to IEC EN62561-2 at page 15 of this catalogue.



Square Clamps According to IEC EN62561-1							
Material	Conductor capacity (mm)			Bolts			Part Number
	round/round	round/flat	flat/flat				
4xM6 stainless steel bolts with threaded base plate model							
Copper	D8-10 / D8-10	D8-10 / 30	30 / 30	M6x20	0.13	50	RC302
Hot-dip galvanized steel	D8-10 / D8-10	D8-10 / 30	30 / 30	M6x20	0.12	50	RCG302
4xM6 stainless steel bolts model							
Tinned copper	D8-10 / D8-10	D8-10 / 30	30 / 30	M6x20	0.14	50	RCE302
Stainless steel	D8-10 / D8-10	D8-10 / 30	30 / 30	M6x20	0.14	50	RI8302
Stainless steel	-	D8-10 / 30	30 / 30	M6x20	0.13	50	RI302
Stainless steel	-	-	30 / 30	M6x20	0.12	50	RIP302



Iron cast inspection pit			
Designation	Kg		Part Number
Iron cast inspection pit with earthing marking on its lid. 250x250x110mm in dimensions Tested according to IEC EN 62561-5, for heavy duty use.	8	1	RF250



"Crows foot" clamp			
Designation	Kg		Part Number
Tinned copper heavy duty clamp to make "crows foot" connection using 30x2 to 30x3.5mm tape conductor. Tightening done using 4xM8 stainless steel bolts. Tested according to IEC EN62561-1 (100kA)	0.60	1	P0302



On-demand fully assembled crows foot conductor			
We manufacture on-demand crows foot conductors using exothermic welding. You can directly unroll them on-site and save time and money. For quotation request, please provide us with: - Type of conductor to be welded (30x2 or 30x3.5mm) - The required length of each conductors to be welded			



Sealing tape			
Designation	Kg		Part Number
The sealing tape is used to protect both outdoor and underground connections. Dimension: 10 meter x 50mm in width	0.70	1	RUBPROT50



Protective spark gap			
Designation	Kg		Part Number
Nominal discharge current (8/20µsec): 25kA Alternative trigger voltage (50Hz): 10kV Lightning peak voltage at 100% (1.2/50µs): 25kV 30x3.5mm outputs in stainless steel with two oblongs holes of 11x13mm, length between axes of 115mm.	0.26	1	ECLMAT



Down conductor warning sign			
According to IEC EN 62305-3			
Designation	Kg		Part Number
Made of aluminium, UV and rain resistant. It is visible from afar and is easily understood. Dimensions: 180x180x3mm with 3x4mm holes.	0.02	1	SIGTERPARA2



Lightning flash counter			
Designation	Kg		Part Number
Detects and counts lightning strokes IP65 protection for outdoor installation I _{max} sup. yo 100kA (8/20µs) Supplied with 2 stainless steel fasteners for mounting on 30x2mm down tape conductor or round with diameter from 8 to 10mm	0.37	1	CF302



Test joint			
Designation	Kg		Part Number
Tinned copper alloy body with stainless steel hardware. For use with tape conductor up to 30mm wide x 2 to 4mm thick. Supplied with hexagonal wrench, dowel screw and anchor for mounting According to IEC EN62561-1.	0.47	1	JC302
PVC base with conductive connection elements in galvanized steel. For use with galvanized steel tape conductor with a width of 30mm or/and galvanized steel round with a dia. from 8 to 12 mm or galvanized steel cable ranging from 50 to 95 mm ² max. According to IEC EN62561-1.	0.33	1	JCG30-D8-12



Anti-vandal metal guard for down tape conductor			
Designation	Kg		Part Number
Hot-dip galvanized anti-vandal metal guard of length 2m for down tape conductor of width 30mm. Provided with its stainless steel wall plugs (x3).	1.20	1	FOP302
Stainless steel anti-vandal metal guard of length 2m for down tape conductor of width 30mm. Provided with its stainless steel wall plugs (x3).	1.20	1	FOP3021
Stainless steel wall plugs	0.04	1	BFOP

Anti-vandal metal guard for round tape conductor			
Designation	Kg		Part Number
Hot-dip galvanized anti-vandal metal guard of length 2m for down round conductor of dia. 8 to 10mm. Provided with its stainless steel wall plugs (x3).	1.00	1	FOP8



Stainless steel push in clips for 6 to 8mm dia. round conductors

Designation	Kg		Part Number
Stainless steel push in clips for 6 to 8mm dia. round conductors with a wall offset of 20mm. M6 Threaded base.	0.014	50	G8201
Stainless steel push in clips for 6 to 8mm dia. round conductors with a wall offset of 30mm. M6 Threaded base.	0.023	50	G8301
Plastic push in clips for 6 to 8mm dia. round conductors with a wall offset of 16mm. M6 Threaded base.	0.008	50	SI6816
Plastic push in clips for 6 to 8mm dia. round conductors with a wall offset of 36mm. M6 Threaded base.	0.015	50	SI6836

"RUBERALU" Bitumen felt roll

Designation	Kg/100		Part Number
Bitumen felt roll to be heated to mount tape conductor on flat roof. Dimensions: 200x45x4mm	0.50	10	RUB302

Holdfast for conductors on flat roof

Designation	(kg)		Part Number
Pyramidal shape, case and bottom part in plastic, filled with concrete. Provided with a conductor holder and 2xM6 stainless steel bolts for tightening tape conductor of 30x2, 30x3.5mm or round with a dia. of 8mm. Dimensions: 140x140x80mm	1	20	PLOP302
Pyramidal shape, case in plastic, provided without bottom part and concrete. Provided with a conductor holder and 2xM6 stainless steel bolts for tightening tape conductor of 30x2, 30x3.5mm or round with a dia. of 8mm. Dimensions: 140x140x80mm	0.08	20	PLOPVIDSF
Pyramidal shape, case and bottom part in plastic, filled with concrete, provided with two threaded M6 holes and with conductor holder. Dimensions: 140x140x80mm	1	20	PLOPNU

Holdfast for flat or round conductors onto flat roof

Designation	Kg		Part Number
Holdfast for flat conductor with a cross section from 30x2 to 30x5mm ² or round conductor with a cross section of 8mm. Delivered with two M6 stainless steel screw.	0.04	20	PLOTSI302



Insulated clips for tape conductors of 30x2mm

Manufactured in UV resistant plastic material, stainless steel hardware.

Designation	Kg		Part Number
Insulated plastic clip for tape conductors from 30x2 to 30x4mm our round conductors of 6 to 8mm dia. Base designed with an oblong hole to ease mounting.	0.025	100	SI302
Insulated plastic clip for tape conductors from 30x2 to 30x4mm our round conductors of 6 to 8mm dia. designed with a M6 threaded base.	0.022	50	SI6302
Insulated plastic clip for tape conductors from 30x2 to 30x4mm our round conductors of 6 to 8mm dia. designed with a 8x40mm screw anchor.	0.024	50	SICH8302



Copper alloy holder for 30mm tape conductors

Designation	Kg		Part Number
Copper alloy clips for tape conductor up to 30mm in width and a thickness from 2 to 6mm max. The base is M8 threaded.	0.10	25	SLT-30



Hot-dip galvanized steel staple

Designation	Kg/100		Part Number
Hot-dip galvanized steel staple to attach flat conductors with a width up to 30mm onto wall surface on a 30mm depth.	2	100 ou 500	CG302
Lead screw anchors for staples	0.5	100	CHP530
Plastic screw anchors for staples	0.05	100	C8



Stainless steel clip for flat conductor

Designation	Kg/100		Part Number
Stainless steel push_in clip for tape conductor with a width of 30mm and a thickness from 2 to 3 mm, the central hole is 4.2mm for mounting with screws or rivets (not provided)	0.250	100 ou 500	CL302
Aluminium/steel Rivet with a dia. of 4x12.5 for steel push-in clip.	0.05	100	CLRIV4x12
Waterproof washer for push-in clip.	0.01	100	CL-JO



Early streamer emission (ESE) air terminal

Early streamer emission (ESE) terminal with 60μsec. triggering advance time (Δt). The strike tip and the high voltage control section are made of stainless steel. The ESE significantly reduce the charge particles ionization process in comparison with standard standard lightning rods. With a total length of 2150mm, its high voltage control section is 1500mm. It is delivered with its collar for an easy mounting on either a 30mm tape or a 8mm dia. round conductor. The ESE complies with the NCF17-102:2011 standard.

Designation	Dimensions	(Kg)		Part Number
Stainless steel ESE terminal	28mm dia. x 2.15m	3,5	1	PDA60
Stainless steel mast extension to elevate the ESE air terminal above 2m (total height of 4.15m)	dia. 33 mm x 2 m	4	1	PDA-MR2M
Stainless steel mast extension to elevate the ESE air terminal above 3m (total height of 5.15m)	33mm dia. x 3m	6	1	PDA-MR3M
Stainless steel mast extension to elevate the ESE air terminal above 5m (total height of 7.15m)	40mm dia. x 2m and 33mm x 3m	12	1	PDA-MR5M

Mounting :

The ESE is installed at a height of 2m min. above the highest structure presents in the protected area. The mounting is straightforward using our mast brackets, mast extension or free-standing air terminal support.

Features:

The protection radius according to NFC 17-102:2011 depends on the height and the level of protection to be reached:

H (m)	2	3	4	5	6	10	15	20	30	45	60
Protection level I	32	48	63	79	79	79	80	80	80	80	80
Protection level II	34	52	69	86	87	88	89	89	90	90	90
Protection level III	39	58	78	97	97	99	101	102	104	105	105
Protection level IV	43	64	86	107	107	109	111	113	116	119	120

Protection radius for installations classified for the protection of the environment (ICPE) :

H (m)	2	3	4	5	6	10	15	20	30	45	60
Protection level I	19	23	37	47	47	47	48	48	48	48	48
Protection level II	20	31	41	52	52	53	53	53	54	54	54
Protection level III	23	35	47	58	58	59	60	61	62	63	63
Protection level IV	26	38	52	64	64	65	65	68	70	71	72



Guy wire kit for air terminal on extension mast

With its PVC coated 25m steel cable of dia. 5mm and accessories, make up to 4 guy ropes of approx. 5m.

Designation	(Kg/100)		Part Number
Guy wire kit	5	1	PDA-KITHAUB

Exothermic Welding

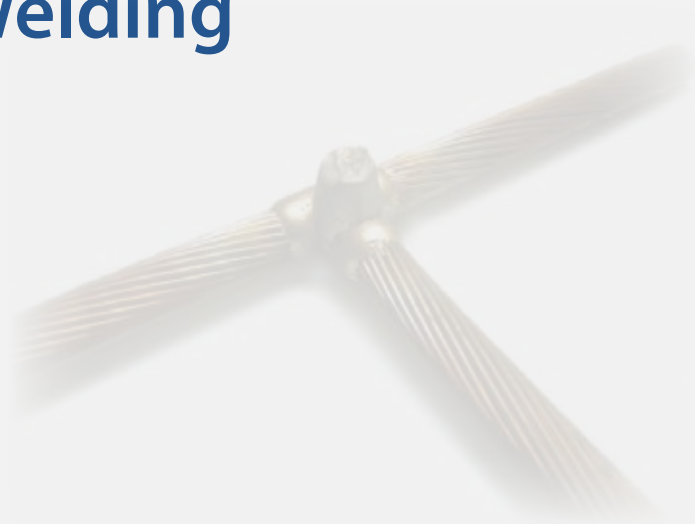



Exothermic welding is a self-sufficient process to achieve high quality electrical connections between metallic conductors such as copper, copper alloy or steel.



The exothermic reaction occurs in a graphite mold manufactured based on the dimensions of the conductors to be welded. A mold can perform over 60 welds when used under normal conditions. The reaction takes only a few seconds and does not require any external source of power, making the exothermic process particularly handy on-site.



Exothermic welding is commonly used when building sub-station earthing circuits, power station, for cathodic protection, lightning protection, utilities and so on as it offers many advantages when compared with traditional crimped or mechanical connections.



The process provides a molecular bond that is not affected by short-circuit current. Several experiments have shown that conductors themselves melt before the exothermic weld point is affected. As the point of fusion of the exothermic connection is substantially identical to copper and with a cross-section superior to the conductors.

Material such as copper alloy, bronze, stainless steel, carbonate steel (railways) can be welded in such way. The weld point is a alloy without any dielectric influences, totally insensitive to corrosion and demonstrating optimum mechanical characteristics with time.

Copper cable and galvanized steel

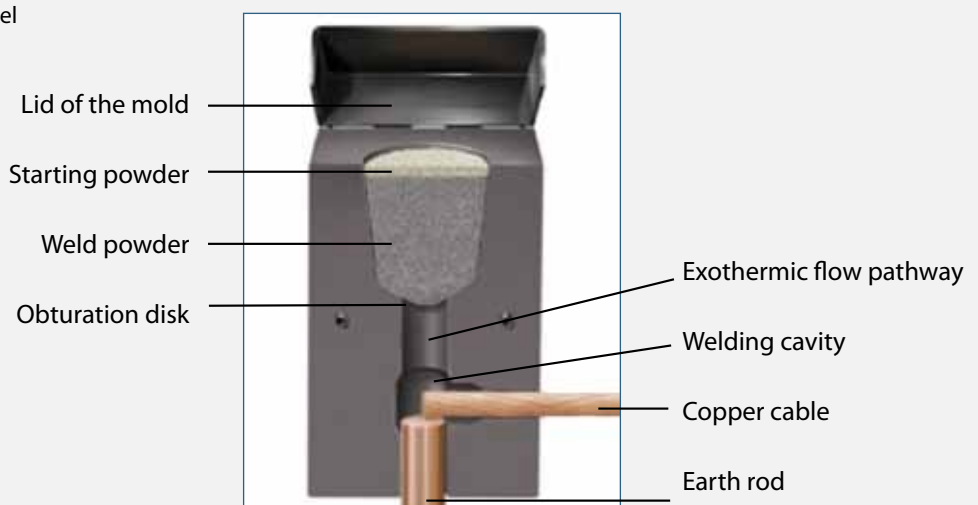

Exothermic welding training
Designation
Our team can provide you with exothermic welding training either on-site or in our office, please contact us for more information.

Weld Selection Guide

Cable to cable

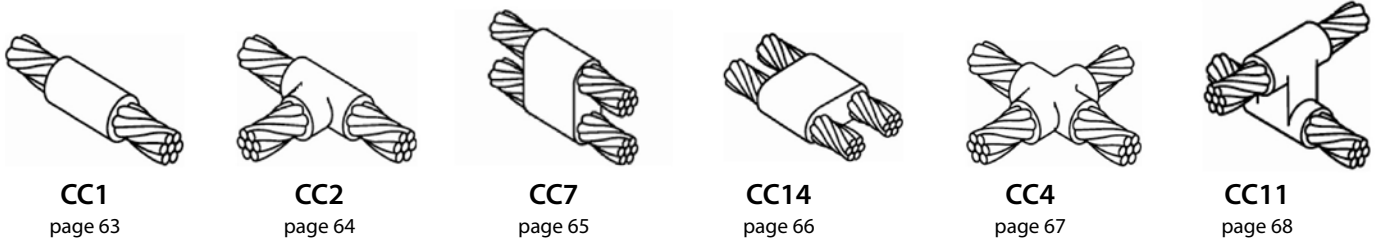

Cable to earth rod

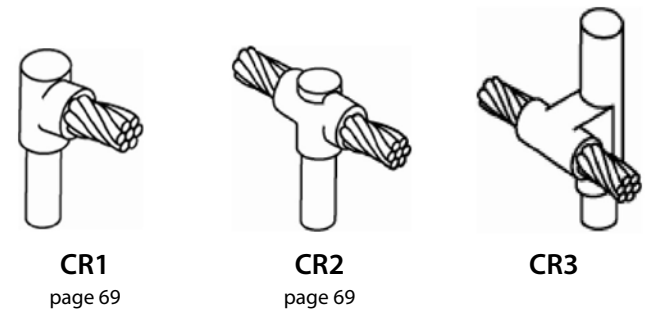

Cable to tape conductor

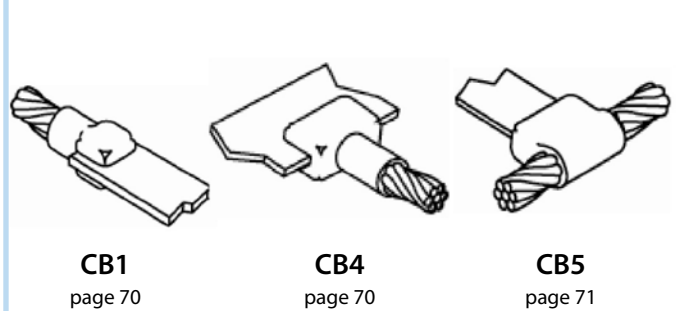

Tape to tape conductor

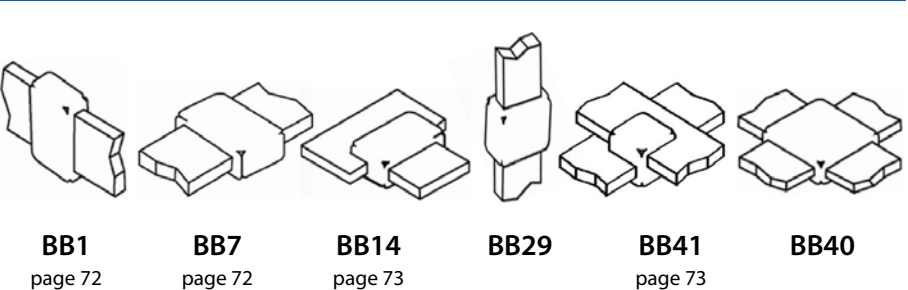

Tape conductor to earth rod

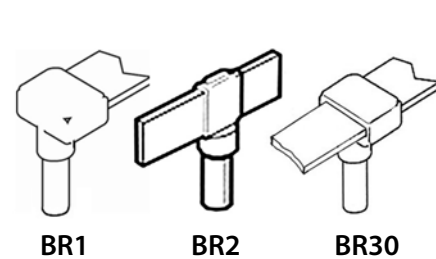

Cable to steel surface

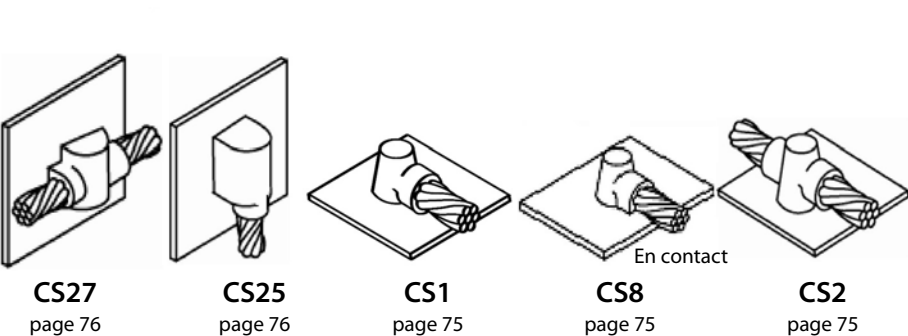

Tape conductor to steel surface

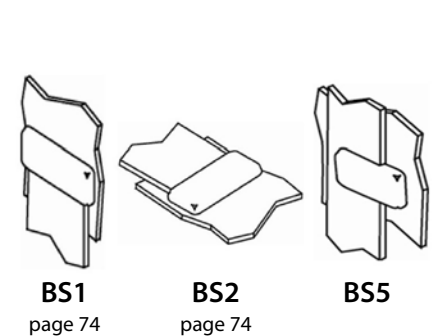

Cable to rebar

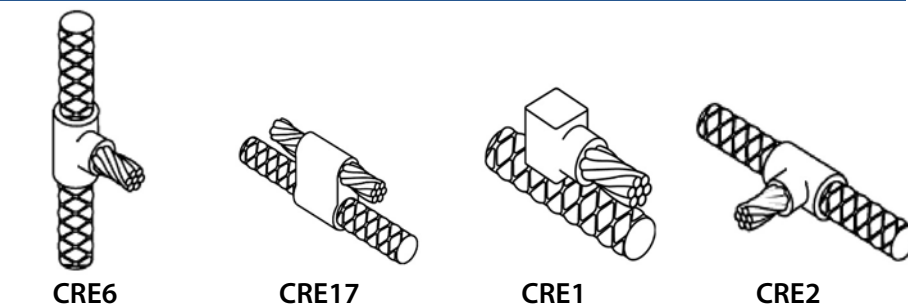

Cable to railway

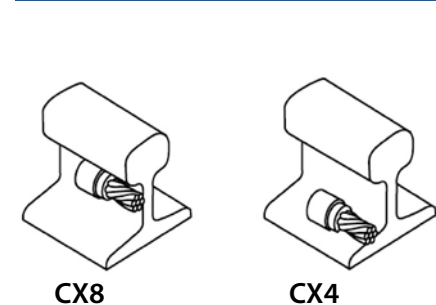

Contact us for more weld configuration

Our mold are designed and manufactured based on the dimensions of cables, tape conductors, earth rod or rebar to be welded. The following tables highlight the main dimensions and characteristics.

Bare copper cable dimensions and characteristics								
Nominal cross section (mm ²)	Number and wire dia. (mm)	Outer dia. (mm)	Number and wire dia. (mm)	Outer dia. (mm)	Number and wire dia. (mm)	Outer dia. (mm)	Number and wire dia. (mm)	Outer dia. (mm)
10	7 x 1.40	4.1	19 x 0.80	4.2	37 x 0.60	4.2		
16	7 x 1.68	5.1	19 x 1.03	5.2	37 x 0.75	5.2		
25	7 x 2.13	6.4	19 x 1.30	6.5	37 x 0.90	6.4		
29			19 x 1.40	7.0				
35	7 x 2.53	7.6	19 x 1.53	7.7	37 x 1.10	7.7		
50	7 x 3	9	19 x 1.83	9.2	37 x 1.31	9.2		
70	7 x 3.56	10.7	19 x 2.17	10.9	37 x 1.55	10.9		
95			19 x 2.50	12.5	37 x 1.81	12.7	61 x 1.40	12.6
120			19 x 2.84	14.2	37 x 2.03	14.2	61 x 1.60	14.4
150			19 x 3.18	15.9	37 x 2.25	16	61 x 1.77	15.9
185					37 x 2.52	17.7		
240					37 x 2.83	19.8		
300					37 x 3.21	22.5		
400							61 x 2.89	26
500							91 x 2.65	29.1

Steel-copper earth rods diameter	
Nominal dimension	Real diameter (mm)
1/2" ou 14 mm	12.5
5/8" ou 16 mm	14.2
3/4" ou 19 mm	17.2

Rebars diameter	
Nominal dimension	Real diameter (mm)
6	6.9
8	9.2
10	11.5
12	13.8
14	16.1
16	18.4
20	23
25	29
28	32
32	37
40	46

Exothermic weld procedure



1. Remove all traces of humidity, grease or oxidation from the conductors or surfaces to be welded.
2. Mount the mold using the appropriate handle clamp model.
3. Before making the first weld, dry the mold using a butane torch. This step is mandatory to avoid a porous weld.
4. Insert with care the conductors to be welded and close the mold appropriately to make sure that no gaps remain as this would lead a leakage of the liquid metal.
5. Place the obturation disk (available with the metal powder box) on top of the exothermic flow pathway.
6. Carefully pore the exothermic welding powder into the crucible (make sure to use the recommended metal powder recommended with the mold). Close the powder pot and tap the bottom to free the ignition powder present at the bottom of the tube.
7. Open the tube and pour the ignition powder onto the exothermic powder, make sure to pour a bit of the ignition powder on the edge of the mold.
8. Close the lid of the mold and approach the flint igniter close to the ignition powder. The operator must be placed on the side and fully respect the safety instructions.
9. Open the mold 1 min. after the exothermic reaction has begun. Remove all traces of scories using the provided scrapper, then clean the welding cavity using the provided brush before making any new welds. As long as the mold remains fry, you can directly go to step 4.



Exothermic powder

Provides starting powder, welding powder as well as the obstruction disk to block the exothermic flow pathway present in the mold.

Designation	Kg		Part Number
Exothermic powder type 45	0.06	20	KW45
Exothermic powder type 65	0.08	20	KW65
Exothermic powder type 90	0.10	20	KW90
Exothermic powder type 115	0.13	10	KW115
Exothermic powder type 150	0.17	10	KW150
Exothermic powder type 200	0.22	10	KW200
Exothermic powder type 250	0.27	10	KW250



Accessories

Designation	Kg		Part Number
Handle clamp for mini mold	0.50	1	HCB00
Handle clamp for standard mold	1.12	1	HCC00
Handle clamp for maxi mold	1.20	1	HCD00
Flint igniter	0.10	1	KAL
Card cloth brush	0.08	1	KBC
Fine mold cleaning brush	0.05	1	KPC
Mold scraper (KW45-KW65)	0.10	1	KG9
Mold scraper (KW90-KW115)	0.10	1	KG10
Mold scraper (KW150-KW250)	0.12	1	KG12
Mold scraper (2 x KW150 and more)	0.12	1	KG13
Sealing compound (band for an easy use)	1.00	1	KMAS
Sealing compound (half box)	0.50	1	KMAS/2
Blow torch piezo	0.530	1	KLAMPE
Universal butane tank for exothermic welding	0.190	1	KCARTOUCHE



Individual protection equipment

Designation	Kg		Part Number
Fireproof leather gloves with sleeves	0.275	1	KGANT
Protective facial screen	0.265	1	KVISIERE

Exothermic welding kit



Get all the required tools to make 20 or 60 welds:

- 1 graphite mold
- 20 or 60 welding powder pots
- 1 handle clamp
- 1 mold scraper
- 1 flint igniter
- 1 box
- 1 flint igniter
- 1 storage case

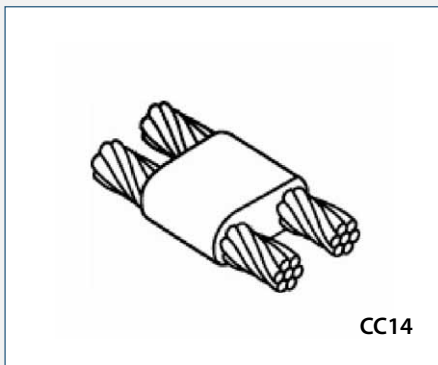

Welding kit for 2 cable in parallel		
Cross section of the cables to be weld	Number of weld	Part Number
25 mm ²	20	20-CC14-25
	60	60-CC14-25
35 mm ²	20	20-CC14-35
	60	60-CC14-35
50 mm ²	20	20-CC14-50
	60	60-CC14-50

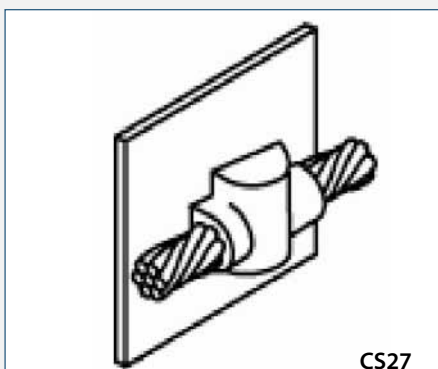

Welding kit for cable on vertical steel surface		
Cross section of the cables to be weld	Number of weld	Part Number
25 mm ²	20	20-CS27-25
	60	60-CS27-25
35 mm ²	20	20-CS27-35
	60	60-CS27-35
50 mm ²	20	20-CS27-50
	60	60-CS27-50

30x2mm tape conductor weld

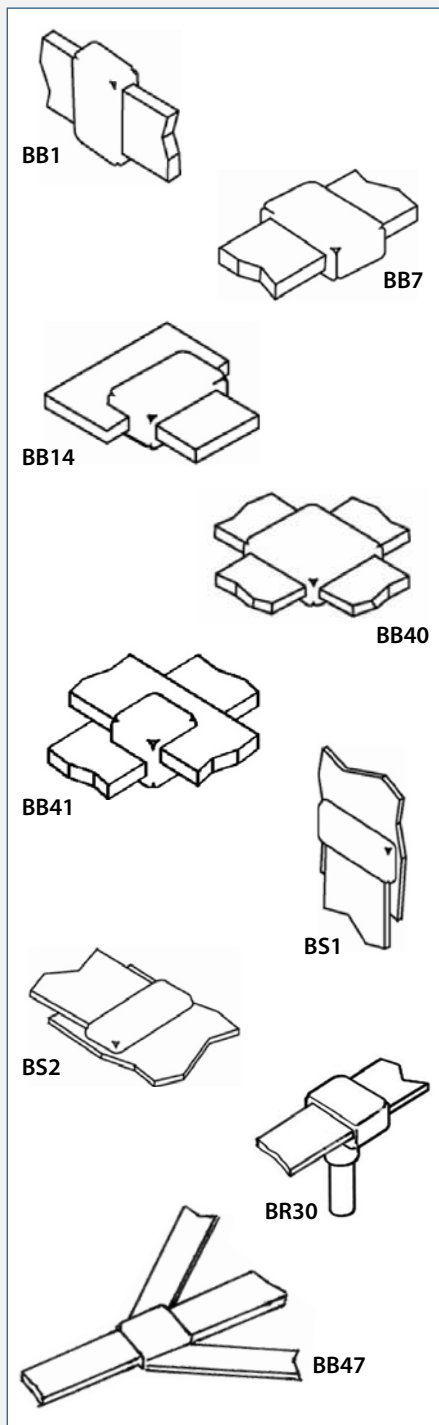

30x2mm tape conductor weld			
Type of weld	Required handle clamp	Required weld powder	Mold Part Number
Horizontal end to end, on the splice	HCB00	KW65	BB1-B-302
Horizontal end to end	HCB00	KW65	BB7-B-302
Horizontal tee	HCB00	KW65	BB14-B-302
Horizontal cross weld (maxi mold)	HCC00	KW90	BB40-C-302
Horizontal cross weld (mini mold)	HCB00	KW65	BB41-B-302
End on vertical steel surface	HCB00	KW90	BS1-B-302
Trough on horizontal steel surface	HCB00	KW90	BS2-B-302
On top of 14.2mm dia. earth rod	HCB00	KW90	BR30-B-143302
On top of 17.2mm dia. earth rod	HCB00	KW90	BR30-B-172302
Crowsfoot weld (maxi mold) with conductor on the slice	HCC00	KW150	BB47V-C-302
Crowsfoot weld (maxi mold) with tape conductor	HCC00	KW200	BB47-C-302

Find out about our 30x2mm tinned copper tape and our whole down conductors product range according to IEC EN62561-2 at page 15 of this catalogue.

Exothermic welding of galvanized steel conductors

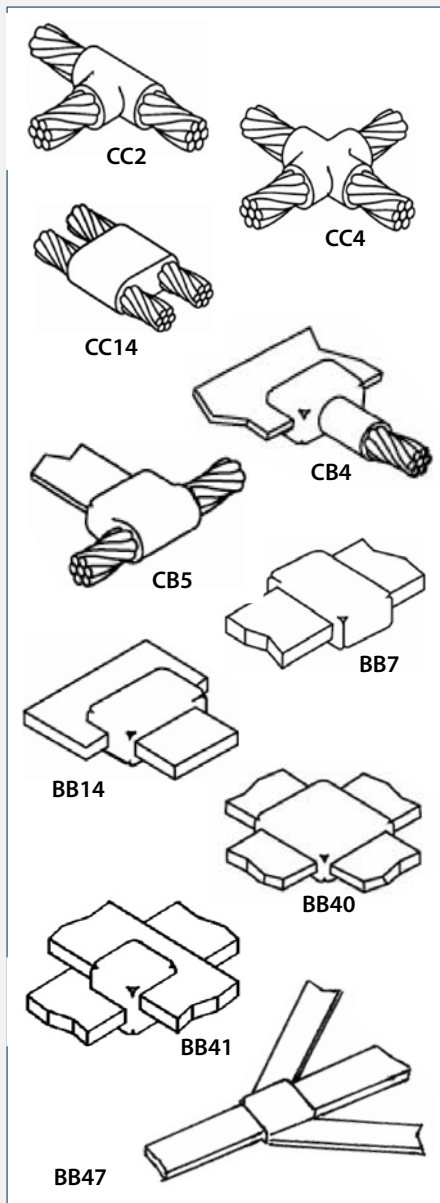

Exothermic welding for 95mm ² bare stranded galvanized steel cable and 30x3.5mm galvanized steel tape conductor			
Type of weld	Required handle clamp	Required weld powder	Mold Part Number
95mm ² cables tee weld	HCC00	KW115	CC2-C-95G
95mm ² cables cross weld	HCC00	KW150	CC4-C-95G
95mm ² cables parallel weld	HCC00	KW150	CC14-C-95G
95mm ² bypass cable on 30x3.5mm on through tape conductor	HCC00	KW90	CB4-C-95G303.5
30x3.5mm bypass tape conductor on 95mm ² trough cable	HCC00	KW150	CB5-C95G303.5
30x3.5mm tape conductor horizontal end to end weld	HCC00	KW90	BB7-C-303.5
30x3.5mm tape conductor horizontal tee weld	HCC00	KW90	BB14-C-303.5
30x3.5mm tape conductor horizontal cross weld	HCC00	KW200	BB40-C-303.5
30x3.5mm tape conductor horizontal cross weld	HCC00	KW115	BB41-C-303.5
30x3.5mm tape conductor crowsfoot weld	HCC00	2x KW150	BB47-C-303.5



Stranded galvanized steel cable (50µm min.)				
Cross Section (mm ²)	Composition	(Kg/m)	(ml)	Part Number
95 mm ²	19 x 2.55	0.80	drums	CG95

Alternative cross sections available on page 12



Galvanized steel tape conductor (70µm min.)				
Dimensions (mm)	Material	(Kg/m)	(ml)	Part Number
30 x 3.5	70µm hot-dip galvanized steel (500 g/m ²)	0.84	30 - 60	AG3035

HORIZONTAL END TO END

CC1

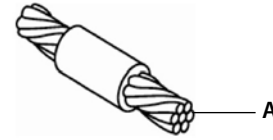

A(mm ²)	Powder	Mold	Pince	Mini mold	Mini handle clamp
10	KW32	CC1-C-10	HCC00	CC1-B-10	HC800
16	KW32	CC1-C-16	HCC00	CC1-B-16	HC800
25	KW32	CC1-C-25	HCC00	CC1-B-25	HC800
35	KW32	CC1-C-35	HCC00	CC1-B-35	HC800
50	KW45	CC1-C-50	HCC00	CC1-B-50	HC800
Ø 8 mm	KW45	CC1-C-D8	HCC00	CC1-B-D8	HC800
70	KW65	CC1-C-70	HCC00	CC1-B-70	HC800
Ø 10 mm	KW65	CC1-C-D10	HCC00	CC1-B-D10	HC800
95	KW90	CC1-C-95	HCC00		
120	KW115	CC1-C-120	HCC00		
150	KW115	CC1-C-150	HCC00		
185	KW150	CC1-C-185	HCC00		
240	KW200	CC1-C-240	HCC00		
300	KW250	CC1-C-300	HCC00		
400	2x KW150	CC1-D-400	HCD00		
500	2x KW200	CC1-D-500	HCD00		

Our graphite mold are highly resistant and can make up to approximately 75 welds when used in normal conditions. There is a specific model of mold per cross sections of conductors and as much types of mold than configurations.

When only a few welds with small conductors sections are required, a mini mold can be used. Cheaper, smaller, it has a life expectancy of 60 weld maximum. They are assembled using the mini handle clamp, however the required quantity of welding powder is identical to our standard molds.

HORIZONTAL TEE

CC2

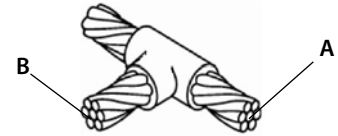

A (mm ²)	B (mm ²)	Powder	Mold	Handle clamp	Mini mold	Mini handle clamp
10	10	KW45	CC2-C-1010	HCC00	CC2-B-1010	HCB00
16	16	KW45	CC2-C-1616	HCC00	CC2-B-1616	HCB00
25	25	KW45	CC2-C-2525	HCC00	CC2-B-2525	HCB00
35	35	KW45	CC2-C-3535	HCC00	CC2-B-3535	HCB00
35	25	KW45	CC2-C-3525	HCC00	CC2-B-3525	HCB00
Ø 8 mm	Ø 8 mm	KW65	CC2-C-D8D8	HCC00	CC2-B-D8D8	HCB00
50	50	KW90	CC2-C-5050	HCC00	CC2-B-5050	HCB00
50	35	KW65	CC2-C-5035	HCC00	CC2-B-5035	HCB00
50	25	KW65	CC2-C-5025	HCC00	CC2-B-5025	HCB00
Ø 10 mm	Ø 10 mm	KW90	CC2-C-D10D10	HCC00	CC2-B-D10D10	HCB00
70	70	KW90	CC2-C-7070	HCC00	CC2-B-7070	HCB00
70	50	KW90	CC2-C-7050	HCC00	CC2-B-7050	HCB00
70	35	KW65	CC2-C-7035	HCC00	CC2-B-7035	HCB00
70	25	KW65	CC2-C-7025	HCC00	CC2-B-7025	HCB00
95	95	KW115	CC2-C-9595	HCC00		
95	70	KW90	CC2-C-9570	HCC00		
95	50	KW90	CC2-C-9550	HCC00		
95	35	KW90	CC2-C-9535	HCC00		
120	120	KW150	CC2-C-120120	HCC00		
120	95	KW150	CC2-C-12095	HCC00		
120	70	KW115	CC2-C-12070	HCC00		
120	50	KW90	CC2-C-12050	HCC00		
150	150	KW200	CC2-C-150150	HCC00		
150	120	KW150	CC2-C-150120	HCC00		
150	95	KW150	CC2-C-15095	HCC00		
150	70	KW115	CC2-C-15070	HCC00		
185	185	KW200	CC2-C-185185	HCC00		
185	150	KW200	CC2-C-185150	HCC00		
185	120	KW200	CC2-C-185120	HCC00		
185	95	KW150	CC2-C-18595	HCC00		
240	240	2x KW150	CC2-C-240240	HCC00		
240	185	KW200	CC2-C-240185	HCC00		
240	150	KW200	CC2-C-240150	HCC00		
240	120	KW200	CC2-C-240120	HCC00		
240	95	KW200	CC2-C-24095	HCC00		
300	300	2x KW200	CC2-D-300300	HCD00		
300	240	2x KW200	CC2-D-300240	HCD00		
300	185	KW250	CC2-C-300185	HCC00		
300	150	KW200	CC2-C-300150	HCC00		

**OVERLAP HORIZONTAL
PARALLEL**

CC7

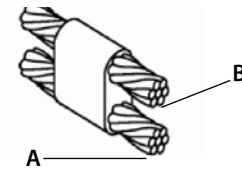

A (mm ²)	B (mm ²)	Powder	Mold	Handle clamp	Mini mold	Mini handle clamp
10	10	KW45	CC7-C-1010	HCC00	CC7-B-1010	HCB00
16	16	KW65	CC7-C-1616	HCC00	CC7-B-1616	HCB00
25	25	KW45	CC7-C-2525	HCC00	CC7-B-2525	HCB00
35	35	KW65	CC7-C-3535	HCC00	CC7-B-3535	HCB00
35	25	KW65	CC7-C-3525	HCC00	CC7-B-3525	HCB00
∅ 8 mm	∅ 8 mm	KW90	CC7-C-D8D8	HCC00	CC7-B-D8D8	HCB00
50	50	KW90	CC7-C-5050	HCC00	CC7-B-5050	HCB00
50	35	KW90	CC7-C-5035	HCC00	CC7-B-5035	HCB00
50	25	KW65	CC7-C-5025	HCC00	CC7-B-5025	HCB00
∅ 10 mm	∅ 10 mm	KW115	CC7-C-D10D10	HCC00		
70	70	KW115	CC7-C-7070	HCC00		
70	50	KW115	CC7-C-7050	HCC00		
70	35	KW90	CC7-C-7035	HCC00	CC7-B-7035	HCB00
70	25	KW90	CC7-C-7025	HCC00	CC7-B-7025	HCB00
95	95	KW150	CC7-C-9595	HCC00		
95	70	KW115	CC7-C-9570	HCC00		
95	50	KW115	CC7-C-9550	HCC00		
95	35	KW115	CC7-C-9535	HCC00		
120	120	KW200	CC7-C-120120	HCC00		
120	95	KW200	CC7-C-12095	HCC00		
120	70	KW150	CC7-C-12070	HCC00		
120	50	KW150	CC7-C-12050	HCC00		
150	150	2x KW150	CC7-D-150150	HCD00		
150	120	KW250	CC7-C-150120	HCC00		
150	95	KW200	CC7-C-15095	HCC00		
150	70	KW150	CC7-C-15070	HCC00		
185	185	2x KW150	CC7-D-185185	HCD00		
185	150	2x KW150	CC7-D-185150	HCD00		
185	120	KW250	CC7-C-185120	HCC00		
185	95	KW200	CC7-C-18595	HCC00		
240	240	2x KW200	CC7-D-240240	HCD00		
240	185	2x KW150	CC7-D-240185	HCD00		
240	150	2x KW150	CC7-D-240150	HCD00		
240	120	KW250	CC7-C-240120	HCC00		
300	300	2x KW250	CC7-D-300300	HCD00		
300	240	2x KW250	CC7-D-300240	HCD00		
300	185	2x KW200	CC7-D-300185	HCD00		
300	150	2x KW150	CC7-D-300150	HCD00		

**SIDE BY SIDE
HORIZONTAL PARALLEL**

CC14

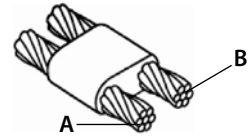

A (mm ²)	B (mm ²)	Powder	Mold	Handle clamp	Mini mold	Mini handle clamp
10	10	KW45	CC14-C-1010	HCC00	CC14-B-1010	HCBO0
16	16	KW65	CC14-C-1616	HCC00	CC14-B-1616	HCBO0
25	25	KW45	CC14-C-2525	HCC00	CC14-B-2525	HCBO0
35	35	KW65	CC14-C-3535	HCC00	CC14-B-3535	HCBO0
35	25	KW65	CC14-C-3525	HCC00	CC14-B-3525	HCBO0
Ø 8 mm	Ø 8 mm	KW90	CC14-C-D8D8	HCC00	CC14-B-D8D8	HCBO0
50	50	KW90	CC14-C-5050	HCC00	CC14-B-5050	HCBO0
50	35	KW90	CC14-C-5035	HCC00	CC14-B-5035	HCBO0
50	25	KW90	CC14-C-5025	HCC00	CC14-B-5025	HCBO0
70	70	KW115	CC14-C-7070	HCC00		
70	50	KW115	CC14-C-7050	HCC00		
70	35	KW90	CC14-C-7035	HCC00	CC14-B-7035	HCBO0
70	25	KW90	CC14-C-7025	HCC00	CC14-B-7025	HCBO0
95	95	KW150	CC14-C-9595	HCC00		
95	75	KW150	CC14-C-9570	HCC00		
95	50	KW150	CC14-C-9550	HCC00		
95	35	KW115	CC14-C-9535	HCC00		
120	120	KW200	CC14-C-120120	HCC00		
120	95	KW200	CC14-C-12095	HCC00		
120	75	KW200	CC14-C-12070	HCC00		
120	50	KW150	CC14-C-12050	HCC00		
150	70	KW200	CC14-C-15070	HCC00		
150	95	KW200	CC14-C-15095	HCC00		
150	120	KW200	CC14-C-150120	HCC00		
150	150	KW250	CC14-C-150150	HCC00		
185	95	KW200	CC14-C-18595	HCC00		
185	120	KW250	CC14-C-185120	HCC00		
185	150	2x KW150	CC14-C-185150	HCC00		
185	185	2x KW150	CC14-C-185185	HCC00		
240	120	2x KW150	CC14-D-240120	HCD00		
240	150	2x KW200	CC14-D-240150	HCD00		
240	185	2x KW200	CC14-D-240185	HCD00		
240	240	2x KW250	CC14-D-240240	HCD00		

HORIZONTAL CROSS

CC4

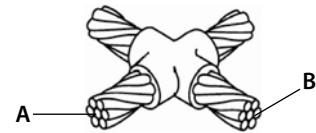

A (mm ²)	B (mm ²)	Powder	Mold	Handle clamp	Mini mold	Mini handle clamp
10	10	KW45	CC4-C-1010	HCC00	CC4-B-1010	HC800
16	16	KW65	CC4-C-1616	HCC00	CC4-B-1616	HC800
25	25	KW45	CC4-C-2525	HCC00	CC4-B-2525	HC800
35	35	KW65	CC4-C-3535	HCC00	CC4-B-3535	HC800
35	25	KW65	CC4-C-3525	HCC00	CC4-B-3525	HC800
Ø 8 mm	Ø 8 mm	KW90	CC4-C-D8D8	HCC00	CC4-B-D8D8	HC800
50	50	KW90	CC4-C-5050	HCC00	CC4-B-5050	HC800
50	35	KW90	CC4-C-5035	HCC00	CC4-B-5035	HC800
50	25	KW90	CC4-C-5025	HCC00	CC4-B-5025	HC800
Ø 10 mm	Ø 10 mm	KW115	CC4-C-D10D10	HCC00		
70	70	KW115	CC4-C-7070	HCC00		
70	50	KW115	CC4-C-7050	HCC00		
70	35	KW115	CC4-C-7035	HCC00		
70	25	KW115	CC4-C-7025	HCC00		
95	95	KW150	CC4-C-9595	HCC00		
95	70	KW150	CC4-C-9570	HCC00		
95	50	KW115	CC4-C-9550	HCC00		
95	35	KW115	CC4-C-9535	HCC00		
120	120	KW200	CC4-C-120120	HCC00		
120	95	KW200	CC4-C-12095	HCC00		
120	70	KW150	CC4-C-12070	HCC00		
120	50	KW150	CC4-C-12050	HCC00		
150	150	KW250	CC4-C-150150	HCC00		
150	120	KW250	CC4-C-150120	HCC00		
150	95	KW200	CC4-C-15095	HCC00		
150	70	KW150	CC4-C-15070	HCC00		
185	185	2x KW150	CC4-C-185185	HCC00		
185	150	KW250	CC4-C-185150	HCC00		
185	120	KW250	CC4-C-185120	HCC00		
185	95	KW200	CC4-C-18595	HCC00		
185	70	KW200	CC4-C-18570	HCC00		
185	50	KW200	CC4-C-18550	HCC00		
185	35	KW150	CC4-C-18535	HCC00		
185	25	KW150	CC4-C-18525	HCC00		
240	240	2x KW250	CC4-D-240240	HCD00		
240	185	2x KW200	CC4-D-240185	HCD00		
240	150	2x KW200	CC4-D-240150	HCD00		
240	120	2x KW150	CC4-D-240120	HCD00		
240	95	2x KW150	CC4-D-24095	HCD00		
240	70	KW250	CC4-C-24070	HCC00		
240	50	KW250	CC4-C-24050	HCC00		

OVERLAP HORIZONTAL CROSS

CC11

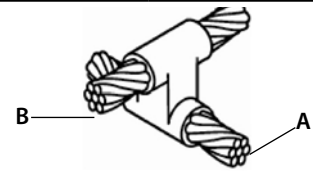

A (mm ²)	B (mm ²)	Powder	Mold	Handle clamp	Mini mold	Mini handle clamp
25	25	KW65	CC11-M-2525	HCC00		
35	35	KW90	CC11-M-3535	HCC00		
50	50	KW150	CC11-M-5050	HCC00		
70	70	KW200	CC11-M-7070	HCC00		
70	50	KW200	CC11-M-7050	HCC00		
70	35	KW150	CC11-M-7035	HCC00		
95	95	KW250	CC11-M-9595	HCC00		
95	70	KW250	CC11-M-9570	HCC00		
95	50	KW200	CC11-M-9550	HCC00		
95	35	KW200	CC11-M-9535	HCC00		
120	120	2x KW150	CC11-M-120120	HCC00		
120	95	2x KW150	CC11-M-12095	HCC00		
120	70	KW250	CC11-M-12070	HCC00		
120	50	KW250	CC11-M-12050	HCC00		
120	35	KW200	CC11-M-12035	HCC00		
150	150	2x KW200	CC11-V-150150	HCD00		
150	120	2x KW200	CC11-V150120	HCD00		
150	95	2x KW150	CC11-M-15095	HCC00		
150	70	2x KW150	CC11-M-15070	HCC00		
150	50	KW250	CC11-M-15050	HCC00		
150	35	KW250	CC11-M-15035	HCC00		
185	185	2x KW250	CC11-V-185185	HCD00		
185	150	2x KW250	CC11-V-185150	HCD00		
185	120	2x KW250	CC11-V-185120	HCD00		
185	95	2x KW200	CC11-V-18595	HCD00		
185	70	2x KW150	CC11-M-18570	HCC00		
185	50	2x KW150	CC11-M-18550	HCC00		
185	35	2x KW150	CC11-M-18535	HCC00		
240	240	3x KW200	CC11-V-240240	HCD00		
240	185	3x KW200	CC11-V-240185	HCD00		
240	150	3x KW200	CC11-V-240150	HCD00		
240	120	3x KW200	CC11-V-240120	HCD00		
240	95	2x KW250	CC11-V-24095	HCD00		
240	70	2x KW250	CC11-V-24070	HCD00		
240	50	2x KW200	CC11-V-24050	HCD00		

CABLE ON TOP OF EARTH ROD

CR1

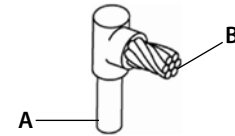

A(mm)	B(mm ²)	Powder	Mold	Handle clamp	Mini mold	Mini handle clamp
14,2	25	KW45	CR1-C-14225	HCC00	CR1-B-14225	HCB00
14,2	35	KW65	CR1-C-14235	HCC00	CR1-B14235	HCB00
14,2	50	KW90	CR1-C-14250	HCC00	CR1-B14250	HCB00
14,2	Ø 8 mm	KW90	CR1-C-142D8	HCC00	CR1-B142D8	HCB00
14,2	70	KW90	CR1-C-14270	HCC00	CR1-B14270	HCB00
14,2	95	KW90	CR1-C-14295	HCC00	CR1-B14295	HCB00
14,2	120	KW90	CR1-C-142120	HCC00	CR1-B142120	HCB00
14,2	150	KW115	CR1-C-142150	HCC00		
14,2	185	KW115	CR1-C-142185	HCC00		
14,2	240	KW150	CR1-C-142240	HCC00		
17,2	25	KW65	CR1-C-17225	HCC00	CR1-B-17225	HCB00
17,2	35	KW65	CR1-C-17235	HCC00	CR1-B-17235	HCB00
17,2	50	KW90	CR1-C-17250	HCC00	CR1-B-17250	HCB00
17,2	Ø 8 mm	KW90	CR1-C-172D8	HCC00	CR1-B-172D8	HCB00
17,2	70	KW90	CR1-C-17270	HCC00	CR1-B-17270	HCB00
17,2	95	KW90	CR1-C-17295	HCC00	CR1-B-17295	HCB00
17,2	120	KW90	CR1-C-172120	HCC00	CR1-B-172120	HCB00
17,2	150	KW115	CR1-C-172150	HCC00		
17,2	185	KW115	CR1-C-172185	HCC00		
17,2	240	KW150	CR1-C-172240	HCC00		
17,2	300	KW200	CR1-C-172300	HCC00		

THROUGH CABLE ON TOP OF EARTH ROD

CR2



A(mm)	B(mm ²)	Powder	Mold	Handle clamp	Mini mold	Mini handle clamp
14,2	25	KW45	CR2-C-14225	HCC00	CR2-B-14225	HCB00
14,2	35	KW90	CR2-C-14235	HCC00	CR2-B-14235	HCB00
14,2	50	KW90	CR2-C-14250	HCC00	CR2-B-14250	HCB00
14,2	Ø 8 mm	KW90	CR2-C-142D8	HCC00	CR2-B142D8	HCB00
14,2	70	KW115	CR2-C-14270	HCC00		
14,2	95	KW115	CR2-C-14295	HCC00		
14,2	120	KW150	CR2-C-142120	HCC00		
14,2	150	KW200	CR2-C-142150	HCC00		
14,2	185	KW200	CR2-C-142185	HCC00		
14,2	240	KW250	CR2-C-142240	HCC00		
17,2	25	KW90	CR2-C-17225	HCC00	CR2-B-17225	HCB00
17,2	35	KW90	CR2-C-17235	HCC00	CR2-B-17235	HCB00
17,2	50	KW115	CR2-C-17250	HCC00		
17,2	Ø 8 mm	KW115	CR2-C-172D8	HCC00		
17,2	70	KW115	CR2-C-17270	HCC00		
17,2	95	KW115	CR2-C-17295	HCC00		
17,2	120	KW150	CR2-C-172120	HCC00		
17,2	150	KW200	CR2-C-172150	HCC00		
17,2	185	KW200	CR2-C-172185	HCC00		
17,2	240	KW250	CR2-C-172240	HCC00		
17,2	300	2x KW150	CR2-D-172300	HCD00		

**END TO END
CABLE TO TAPE CONDUCTOR**

CB1

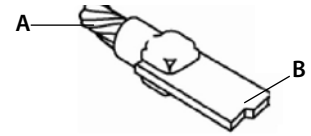

A (mm ²)	B (mm x mm)	Powder	Mold	Handle clamp	Mini mold	Mini handle clamp
25	20x2	KW32	CB1-C-25202	HCC00	CB1-B-25202	HCB00
35	20x2	KW32	CB1-C-35202	HCC00	CB1-B-35202	HCB00
50	25x2	KW45	CB1-C-50252	HCC00	CB1-B-50252	HCB00
50	25x3	KW65	CB1-C-50253	HCC00	CB1-B-50253	HCB00
Ø 8 mm	25x2	KW45	CB1-C-D8252	HCC00	CB1-B-D8252	HCB00
Ø 8 mm	25x3	KW65	CB1-C-D8253	HCC00	CB1-B-D8253	HCB00
70	25x3	KW65	CB1-C-70253	HCC00	CB1-B-70253	HCB00
70	25x4	KW65	CB1-C-70254	HCC00	CB1-B-70254	HCB00
Ø 10 mm	25x3	KW65	CB1-C-D10253	HCC00	CB1-B-D10253	HCB00
Ø 10 mm	25x4	KW65	CB1-C-D10254	HCC00	CB1-B-D10254	HCB00
95	25x4	KW90	CB1-C-95254	HCC00	CB1-B-95254	HCB00
95	25x5	KW90	CB1-C-95255	HCC00	CB1-B-95255	HCB00
120	25x5	KW90	CB1-C-120255	HCC00	CB1-B-120255	HCB00
120	30x5	KW115	CB1-C-120305	HCC00		
120	40x5	KW115	CB1-C-120405	HCC00		
150	30x5	KW115	CB1-C-150305	HCC00		
150	40x5	KW150	CB1-C-150405	HCC00		
185	40x5	KW150	CB1-C-185405	HCC00		
185	50x5	KW200	CB1-D-185505	HCD00		
240	50x5	KW200	CB1-D-240505	HCD00		
240	50x6	2x KW150	CB1-D-240506	HCD00		
300	50x6	2x KW150	CB1-D-300506	HCD00		
300	50x8	2x KW150	CB1-D-300508	HCD00		

**BYPASS CABLE TO TAPE
CONDUCTOR**

CB4

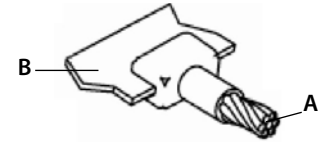

A (mm ²)	B (mm x mm)	Powder	Mold	Handle clamp	Mini mold	Mini handle clamp
25	20x2	KW25	CB4-C-25202	HCC00	CB4-B-25202	HCB00
35	20x2	KW32	CB4-C-35202	HCC00	CB4-B-35202	HCB00
50	25x2	KW45	CB4-C-50252	HCC00	CB4-B-50252	HCB00
50	25x3	KW45	CB4-C-50253	HCC00	CB4-B-50253	HCB00
Ø 8 mm	25x2	KW45	CB4-C-D8252	HCC00	CB4-B-D8252	HCB00
Ø 8 mm	25x3	KW45	CB4-C-D8253	HCC00	CB4-B-D8253	HCB00
70	25x3	KW65	CB4-C-70253	HCC00	CB4-B-70253	HCB00
70	25x4	KW65	CB4-C-70254	HCC00	CB4-B-70254	HCB00
Ø 10 mm	25x3	KW65	CB4-C-D10253	HCC00	CB4-B-D10253	HCB00
Ø 10 mm	25x4	KW65	CB4-C-D10254	HCC00	CB4-B-D10254	HCB00
95	25x4	KW90	CB4-C-95254	HCC00	CB4-B-95254	HCB00
95	25x5	KW90	CB4-C-95255	HCC00	CB4-B-95255	HCB00
120	25x5	KW90	CB4-C-120255	HCC00	CB4-B-120255	HCB00
120	30x5	KW115	CB4-C-120305	HCC00		
120	40x5	KW115	CB4-C-120405	HCC00		
150	30x5	KW115	CB4-C-150305	HCC00		
150	40x5	KW115	CB4-C-150405	HCC00		
185	40x5	KW150	CB4-C-185405	HCC00		
185	50x5	KW150	CB4-C-185505	HCC00		
240	50x5	KW200	CB4-C-240505	HCC00		
240	50x6	KW250	CB4-C-240506	HCC00		
300	50x6	2x KW150	CB4-D-300506	HCD00		
300	50x8	2x KW200	CB4-D-300508	HCD00		

**BYPASS TAPE CONDUCTOR
TO CABLE**

CB5

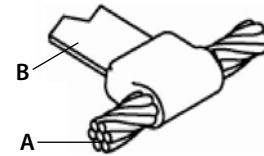

A (mm ²)	B (mm x mm)	Powder	Mold	Handle clamp	Mini mold	Mini handle clamp
10	20x2	KW45	CB5-C-10202	HCC00	CB5-B-10202	HCB00
16	20x2	KW45	CB5-C-16202	HCC00	CB5-B-16202	HCB00
25	20x2	KW45	CB5-C-25202	HCC00	CB5-B-25202	HCB00
35	20x2	KW45	CB5-C-35202	HCC00	CB5-B-35202	HCB00
50	25x2	KW65	CB5-C-50252	HCC00	CB5-B-50252	HCB00
50	25x3	KW65	CB5-C-50253	HCC00	CB5-B-50253	HCB00
Ø 8 mm	25x2	KW65	CB5-C-D8252	HCC00	CB5-B-D8252	HCB00
Ø 8 mm	25x3	KW65	CB5-C-D8253	HCC00	CB5-B-D8253	HCB00
70	25x3	KW90	CB5-C-70253	HCC00	CB5-B-70253	HCB00
70	25x4	KW115	CB5-C-70254	HCC00		
Ø 10 mm	25x3	KW115	CB5-C-D10253	HCC00		
Ø 10 mm	25x4	KW150	CB5-C-D10254	HCC00		
95	25x4	KW150	CB5-C-95254	HCC00		
95	25x5	KW150	CB5-C-95255	HCC00		
120	25x5	KW150	CB5-C-120255	HCC00		
120	30x5	KW200	CB5-C-120305	HCC00		
150	30x5	KW200	CB5-C-150305	HCC00		
150	40x5	KW250	CB5-C-150405	HCC00		
185	40x5	KW250	CB5-C-185405	HCC00		
185	50x5	2x KW150	CB5-D-185505	HCD00		
240	50x5	2x KW150	CB5-D-240505	HCD00		
240	50x6	2x KW200	CB5-D-240506	HCD00		
300	50x6	2x KW250	CB5-D-300506	HCD00		
300	50x8	2x KW250	CB5-D-300508	HCD00		

HORIZONTAL ON THE SPLICE END TO END TAPE CONDUCTOR

BB1

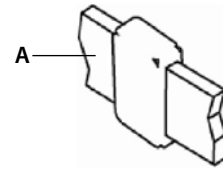

A (mm x mm)	Powder	Mold	Handle clamp	Mini mold	Mini handle clamp
20x2	KW45	BB1-C-202	HCC00	BB1-B-202	HCBO0
20x3	KW45	BB1-C-203	HCC00	BB1-B-203	HCBO0
25x2	KW65	BB1-C-252	HCC00	BB1-B-252	HCBO0
25x3	KW65	BB1-C-253	HCC00	BB1-B-253	HCBO0
25x4	KW90	BB1-C-254	HCC00	BB1-B-254	HCBO0
30x2	KW65	BB1-C-302	HCC00	BB1-B-302	HCBO0
30x3	KW90	BB1-C-303	HCC00	BB1-B-303	HCBO0
30x4	KW115	BB1-C-304	HCC00		
30x5	KW115	BB1-C-305	HCC00		
40x3	KW115	BB1-C-403	HCC00		
40x4	KW150	BB1-C-404	HCC00		
40x5	KW150	BB1-C-405	HCC00		
40x6	KW200	BB1-C-406	HCC00		
50x5	KW200	BB1-C-505	HCC00		
50x6	KW250	BB1-C-506	HCC00		
50x8	2x KW150	BB1-D-508	HCD00		
60x6	KW250	BB1-C-606	HCC00		
60x8	2x KW200	BB1-D-608	HCD00		
60x10	2x KW250	BB1-D-6010	HCD00		
80x6	2x KW200	BB1-D-806	HCD00		
80x8	2x KW250	BB1-D-808	HCD00		
80x10	3x KW200	BB1-D-8010	HCD00		

HORIZONTAL END TO END TAPE CONDUCTOR

BB7

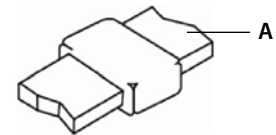

A (mm x mm)	Powder	Mold	Handle clamp	Mini mold	Mini handle clamp
20x2	KW45	BB7-C-202	HCC00	BB7-B-202	HCBO0
20x3	KW45	BB7-C-203	HCC00	BB7-B-203	HCBO0
20x4	KW65	BB7-C-204	HCC00	BB7-B-204	HCBO0
20x5	KW90	BB7-C-205	HCC00	BB7-B-205	HCBO0
25x2	KW45	BB7-C-252	HCC00	BB7-B-252	HCBO0
25x3	KW65	BB7-C-253	HCC00	BB7-B-253	HCBO0
25x4	KW90	BB7-C-254	HCC00	BB7-B-254	HCBO0
25x5	KW90	BB7-C-255	HCC00	BB7-B-255	HCBO0
30x2	KW65	BB7-C-302	HCC00	BB7-B-302	HCBO0
30x3	KW65	BB7-C-303	HCC00	BB7-B-303	HCBO0
30x4	KW90	BB7-C-304	HCC00	BB7-B-304	HCBO0
30x5	KW115	BB7-C-305	HCC00		
40x3	KW90	BB7-C-403	HCC00		
40x4	KW115	BB7-C-404	HCC00		
40x5	KW150	BB7-C-405	HCC00		
40x6	KW200	BB7-C-406	HCC00		
50x5	KW200	BB7-D-505	HCD00		
50x6	KW250	BB7-D-506	HCD00		
50x8	2x KW150	BB7-D-508	HCD00		
60x6	2x KW150	BB7-D-606	HCD00		
60x8	2x KW200	BB7-D-608	HCD00		
60x10	2x KW250	BB7-D-6010	HCD00		

HORIZONTAL TEE TAPE CONDUCTOR

BB14

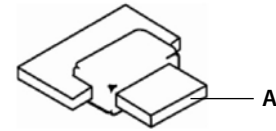

A (mm x mm)	Powder	Mold	Handle clamp	Mini mold	Mini handle clamp
20x2	KW45	BB14-C-202	HCC00	BB14-B-202	HC800
20x3	KW45	BB14-C-203	HCC00	BB14-B-203	HC800
20x4	KW65	BB14-C-204	HCC00	BB14-B-204	HC800
20x5	KW90	BB14-C-205	HCC00	BB14-B-205	HC800
25x2	KW45	BB14-C-252	HCC00	BB14-B-252	HC800
25x3	KW65	BB14-C-253	HCC00	BB14-B-253	HC800
25x4	KW90	BB14-C-254	HCC00	BB14-B-254	HC800
25x5	KW90	BB14-C-255	HCC00	BB14-B-255	HC800
30x2	KW65	BB14-C-302	HCC00	BB14-B-302	HC800
30x3	KW65	BB14-C-303	HCC00	BB14-B-303	HC800
30x4	KW90	BB14-C-304	HCC00	BB14-B-304	HC800
30x5	KW115	BB14-C-305	HCC00		
40x3	KW90	BB14-C-403	HCC00		
40x4	KW115	BB14-C-404	HCC00		
40x5	KW150	BB14-C-405	HCC00		
40x6	KW200	BB14-C-406	HCC00		
50x5	KW200	BB14-D-505	HCD00		
50x6	KW250	BB14-D-506	HCD00		
50x8	2x KW150	BB14-D-508	HCD00		
60x6	2x KW150	BB14-D-606	HCD00		
60x8	2x KW200	BB14-D-608	HCD00		
60x10	2x KW250	BB14-D-6010	HCD00		

HORIZONTAL CROSS TAPE CONDUCTOR

BB41



A (mm x mm)	Powder	Mold	Handle clamp	Mini mold	Mini handle clamp
20x2	KW45	BB41-C-202	HCC00	BB41-B-202	HC800
20x3	KW65	BB41-C-203	HCC00	BB41-B-203	HC800
20x5	KW65	BB41-C-205	HCC00	BB41-B-205	HC800
25x2	KW65	BB41-C-252	HCC00	BB41-B-252	HC800
25x3	KW65	BB41-C-253	HCC00	BB41-B-253	HC800
25x4	KW90	BB41-C-254	HCC00	BB41-B-254	HC800
30x2	KW65	BB41-C-302	HCC00	BB41-B-302	HC800
30x3	KW90	BB41-C-303	HCC00	BB41-B-303	HC800
30x4	KW115	BB41-C-304	HCC00		
30x5	KW115	BB41-C-305	HCC00		
40x3	KW150	BB41-C-403	HCC00		
40x4	KW200	BB41-C-404	HCC00		
40x5	KW200	BB41-C-405	HCC00		
40x6	KW200	BB41-C-406	HCC00		
40x10	KW250	BB41-C-410	HCC00		
50x5	KW200	BB41-C-505	HCC00		
50x6	KW200	BB41-C-506	HCC00		
50x8	KW250	BB41-C-508	HCC00		
50x10	2x KW150	BB41-D-5010	HCD00		

**VERTICAL CROSS TAPE
CONDUCTOR ON VERTICAL
STEEL SURFACE**

BS1

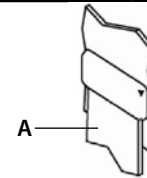

A (mm x mm)	Powder	Mold	Handle clamp	Mini mold	Mini handle clamp
20x2	KW65	BS1-C-202	HCC00	BS1-B-202	HC800
20x3	KW65	BS1-C-203	HCC00	BS1-B-203	HC800
25x2	KW90	BS1-C-252	HCC00	BS1-B-252	HC800
25x3	KW90	BS1-C-253	HCC00	BS1-B-253	HC800
25x4	KW90	BS1-C-254	HCC00	BS1-B-254	HC800
30x2	KW90	BS1-C-302	HCC00	BS1-B-302	HC800
30x3	KW90	BS1-C-303	HCC00	BS1-B-303	HC800
30x4	KW115	BS1-C-304	HCC00		
30x5	KW150	BS1-C-305	HCC00		
40x3	KW150	BS1-C-403	HCC00		
40x4	KW200	BS1-C-404	HCC00		
40x5	KW200	BS1-C-405	HCC00		
40x6	KW250	BS1-C-406	HCC00		
50x5	KW250	BS1-C-505	HCC00		
50x6	2x KW150	BS1-D-506	HCD00		
50x8	2x KW200	BS1-D-508	HCD00		
60x6	2x KW200	BS1-D-606	HCD00		
60x8	2x KW250	BS1-D-608	HCD00		
60x10	3x KW200	BS1-D-6010	HCD00		
80x6	2x KW250	BS1-D-806	HCD00		
80x8	3x KW200	BS1-D-808	HCD00		
80x10	3x KW250	BS1-D-8010	HCD00		

**HORIZONTAL TAPE
CONDUCTOR ON
HORIZONTAL STEEL SURFACE**

BS2

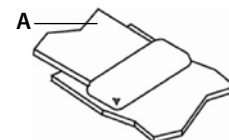

A (mm x mm)	Powder	Mold	Handle clamp	Mini mold	Mini handle clamp
20x2	KW65	BS2-C-202	HCC00	BS2-B-202	HC800
20x3	KW90	BS2-C-203	HCC00	BS2-B-203	HC800
25x2	KW90	BS2-C-252	HCC00	BS2-B-252	HC800
25x3	KW90	BS2-C-253	HCC00	BS2-B-253	HC800
25x4	KW90	BS2-C-254	HCC00	BS2-B-254	HC800
30x2	KW90	BS2-C-302	HCC00	BS2-B-302	HC800
30x3	KW115	BS2-C-303	HCC00		
30x4	KW150	BS2-C-304	HCC00		
30x5	KW200	BS2-C-305	HCC00		
40x3	KW115	BS2-C-403	HCC00		
40x4	KW200	BS2-C-404	HCC00		
40x5	KW200	BS2-C-405	HCC00		
40x6	KW250	BS2-C-406	HCC00		
50x5	2x KW150	BS2-D-505	HCD00		
50x6	2x KW150	BS2-D-506	HCD00		
50x8	2x KW200	BS2-D-508	HCD00		

HORIZONTAL CABLE ON HORIZONTAL STEEL SURFACE

CS1

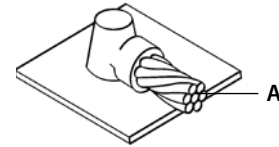

A (mm)	Powder	Mold	Handle clamp	Mini mold	Mini handle clamp
50	KW90	CS1-C-50	HCC00	CS1-B-50	HCB00
70	KW90	CS1-C-70	HCC00	CS1-B-70	HCB00
95	KW115	CS1-C-95	HCC00	CS1-B-95	HCB00
120	KW115	CS1-C-120	HCC00		
150	KW150	CS1-C-150	HCC00		
185	KW200	CS1-C-185	HCC00		
240	KW200	CS1-C-240	HCC00		
300	KW250	CS1-C-300	HCC00		

HORIZONTAL TROUGH CABLE ON HORIZONTAL STEEL SURFACE

CS2

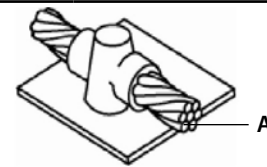

A (mm ²)	Powder	Mold	Handle clamp	Mini mold	Mini handle clamp
25	KW45	CS2-C-25	HCC00	CS2-B-25	HCB00
35	KW45	CS2-C-35	HCC00	CS2-B-35	HCB00
50	KW90	CS2-C-50	HCC00	CS2-B-50	HCB00
∅ 8 mm	KW90	CS2-C-D8	HCC00	CS2-B-D8	HCB00
70	KW115	CS2-C-70	HCC00		
∅ 10 mm	KW115	CS2-C-D10	HCC00		
95	KW115	CS2-C-95	HCC00		
120	KW150	CS2-C-120	HCC00		
150	KW200	CS2-C-150	HCC00		
185	KW250	CS2-C-185	HCC00		
240	2x KW150	CS2-D-240	HCD00		
300	2x KW200	CS2-D-300	HCD00		

HORIZONTAL CABLE IN CONTACT WITH HORIZONTAL STEEL SURFACE

CS8

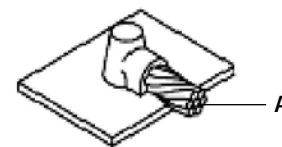

A (mm ²)	Powder	Mold (*)	Handle clamp	Mini mold (*)	Mini handle clamp
16	KW45	CS8-C-16	HCC00	CS8-B-16	HCB00
25	KW45	CS8-C-25	HCC00	CS8-B-25	HCB00
35	KW45	CS8-C-35	HCC00	CS8-B-35	HCB00
50	KW65	CS8-C-50	HCC00	CS8-B-50	HCB00
70	KW65	CS8-C-70	HCC00	CS8-B-70	HCB00
95	KW90	CS8-C-95	HCC00	CS8-B-95	HCB00
120	KW115	CS8-C-120	HCC00		
150	KW150	CS8-C-150	HCC00		
185	KW200	CS8-C-185	HCC00		
240	KW200	CS8-C-240	HCC00		
300	KW250	CS8-C-300	HCC00		

(*) The use of sealing compound (our part number KMAS) is mandatory to perform such weld.

VERTICAL CABLE ON VERTICAL STEEL SURFACE

CS25

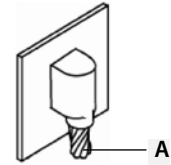

A (mm ²)	Powder	Mold (*)	Handle clamp	Mini mold (*)	Mini handle clamp
25	KW45	CS25-C-25	HCC00	CS25-B-25	HCB00
35	KW45	CS25-C-35	HCC00	CS25-B-35	HCB00
50	KW65	CS25-C-50	HCC00	CS25-B-50	HCB00
70	KW90	CS25-C-70	HCC00	CS25-B-70	HCB00
95	KW115	CS25-C-95	HCC00		
120	KW115	CS25-C-120	HCC00		
150	KW150	CS25-C-150	HCC00		
185	KW200	CS25-C-185	HCC00		
240	KW200	CS25-C-240	HCC00		
300	KW250	CS25-C-300	HCC00		

(*) The use of sealing compound (our part number KMAS) is mandatory to perform such weld.

VERTICAL TROUGH CABLE ON VERTICAL STEEL SURFACE

CS27

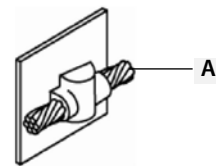

A (mm ²)	Powder	Mold (*)	Handle clamp	Mini mold (*)	Mini handle clamp
25	KW45	CS27-C-25	HCC00	CS27-B-25	HCB00
35	KW45	CS27-C-35	HCC00	CS27-B-35	HCB00
50	KW65	CS27-C-50	HCC00	CS27-B-50	HCB00
70	KW115	CS27-C-70	HCC00		
95	KW150	CS27-C-95	HCC00		
120	KW150	CS27-C-120	HCC00		
150	KW200	CS27-C-150	HCC00		
185	KW250	CS27-D-185	HCC00		
240	2 x KW150	CS27-C-240	HCD00		
300	2 x KW200	CS27-C-300	HCD00		

(*) The use of sealing compound (our part number KMAS) is mandatory to perform such weld.

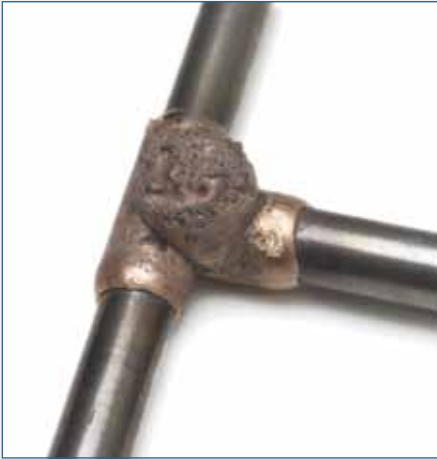

On-demand exothermic welds



We can manufacture molds for specific exothermic weld configuration out of our standard.

Please provide us with:

- The nature of the conductors (shape, composition)
- The dimensions of the conductors (diameter (real), cross section)
- The nature of the element to be welded (composition)
- The position of the element to be welded (horizontal plan is the best)
- The number of weld points to be done.

Note that most of the materials such as copper and copper alloy, stainless steel, galvanized steel, bronze are suitable when doing exothermic welding. However, aluminium cannot be used.



Example of a 120mm² bare copper wire grid made using exothermic welding for substation.

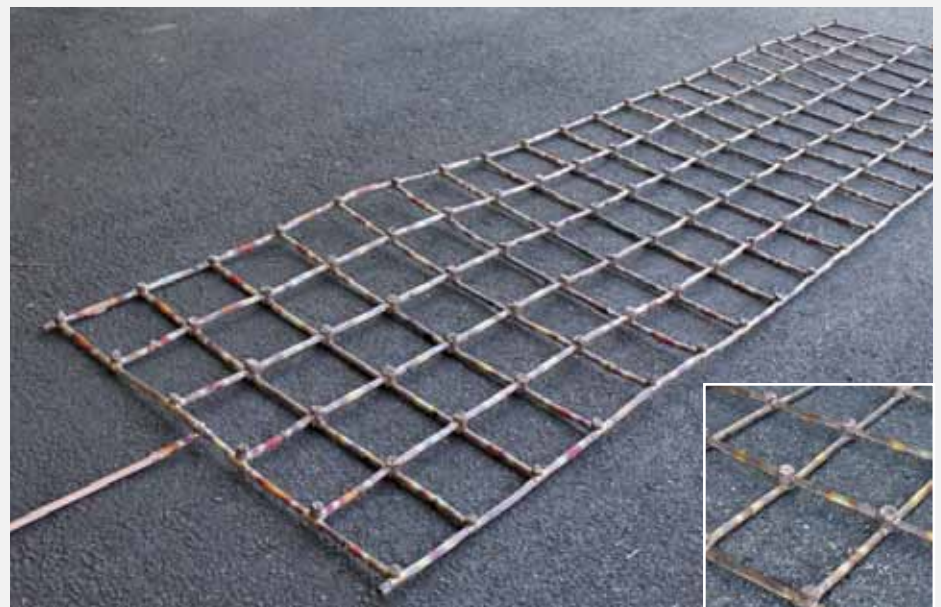

Prefix	Product description	Page (s)
Earthing, bonding and lightning protection		
2CLPAR	Double winged earth clamps	30
2CLPAR...L	Double winged earth clamp	41
2CPAR	Double earth clamp	31
2CPAR...L	Double earth clamp	41
A...	Staples	37
AG...	Flat conductors	15
AL303	Flat conductors	15
BET...	Equipotential bonding bars	21
BFOP	Stainless steel wall plugs	51
BOU	Earth rod drive sleeve	16
BT...	Disconnecting links	20
C...	Plastic screws anchors	35
C...	Copper C crimp connectors	27
CC...VJ	Semi-rigid insulated yellow/green stranded copper cable	13
CCR...	Stranded bare copper cable	12
CCS...VJ	Flexible insulated yellow/green stranded copper cable	13
CD...	Straight cable terminal lugs	26
CDC	Stainless steel cross bracket	46
CE...	Flat angle bracket cable lugs	26
CF302	Lightning flash counter	51
CFD	Hot-dip galvanized steel lateral bracket	46
CG...	Hot-dip galvanized steel cable	12
CG302	Hot-dip galvanized steel staple	53
CHP	Lead screw anchors for staples	53
Cl...	Stainless steel zip ties	36
CL302	Stainless steel push-in clip for tape conductor	53
CL-JO	Waterproof washer for push-in clip	53
CLPAR...	Winged earth clamps	30
CLPAR...L	Winged earth clamp	41
CLRIV4x12	Aluminium/steel Rivet	53
CMT...	Earthing collars	22
COS...	Earth rod clamps	18
COS2E	Stainless steel lightning rod and mast bracket	46
COSE-D10G	Clamp for tape or round conductor	22
COT...	Tinned copper tubular compression lugs	25
COTD...	Straight compression lugs with long barrel for earth cables	42
COTALCU	Copper/Aluminium compression lugs	24
CP...	Zip ties	36
CPAR...	Earth clamp	31
CPAR...L	Earth clamp	41
CT...	Tee shape lugs	26
CT3	Gripped tie gun for zip ties installation	36
CU...	Flat conductors	15
ECI8	Stainless steel hasp	37
ECLMAT	Protective spark gap	50
EMBM16I	Lightning rod base	47
F...	Stainless steel ribbon ties	37
FOP...	Anti-vandal metal guard for tape conductor	51
G...I	Stainless steel push in clips	52
GC...	Copper earth grid	19
GOUJON...	Copper alloy stud and nut	28
GPEA...	Waterproof heavy dual wall duty heat shrink tube	32
GPF...	Small duty heat shrink tube	32
GPH519I...	Terminal clamps on steel structure	22
GPMA...	Waterproof regular dual wall duty heat shrink tube	32
HUM...-LAI	Copper alloy stud and nut	28, 35
I...	Hard drawn conductors	15
IFFM...	Low voltage insulators (female/female)	20
JC302	Test joint	51
JCG30...	PVC base with conductive connection elements	51
KS610-AL	Aluminium connector for round conductors	29
MCL...	Coupler for bonding cable	42
MC...	Copper alloy or bronze earth rod coupler for standard earth rods	17
MF...	Copper alloy or bronze coupling for threaded earth rods	17
MR...	Stainless steel mast extension	46
MS450I	Clamp for equipotential bonding on steel surface	22
MVCU8-10	Copper clamp for round conductor or earth point	48
MVG...	Fixed earth terminal clamps for cables or rebars	23
MV18-10	Stainless steel clamp for round conductor or earth point	48
OPL	Gripped tie gun	37
PBM...	Copper / Aluminium bi-metallic plates	30
PC...	Standard earth rods 250 µm	17
PCA...	Stainless steel air terminal,	47
PCE...A	350µm copper-bonded steel earth rods	18
PDA	Early streamer emission (ESE) air terminal	54
PDA-KITHAUB	Guy kit for air terminal on extension mast	54
PDA-MR...	Stainless steel mast extension for ESE	54
PEPIx	Stainless steel squared plate	47
PFC	Push-in zip ties mount	36
PFD	Hot-dip galvanized steel bracket	46
Pl...	Stainless steel earth rods	16
PLC	Coper earth plates	19
PLD...	U-bolt mast bracket on	46
PLOP...	Holdfast for conductors on flat roof	52
PLOTSI302	Holdfast for flat or round conductors onto flat roof	52
PO302	"Crows foot" clamp	50

Prefix	Product description	Page (s)
PPCIx	Stainless steel squared plate	47
PT...	Perforated copper bars,	14
PT300-10	Bare copper earthing plate,	21
PTI300-10	Copper earthing plate mounted on insulators	21
PTCM...	Stainless steel fixed earth terminal for concrete installation	23
PTS...	Lightning rod	46
PV...	Dowel screws	35
RAG	Cable clamps	33
RBM...	Copper/aluminium bi-metallic washers	28,31
RC...	Heavy duty square clamps	48,49
RD...	Straight shape cable lugs	26
RD30/8-10	Heavy duty square clamps	23
RD40/1040	Connection clamp for tape or round conductor to rebars	23
RDEL...-A2	A2 stainless steel washers,	34
RDEL...-LAI	Copper alloy washers	35
RDELW...-A2	A2 stainless steel grower washers	34
RF250	Iron cast inspection pit	50
RFB...	Clamp for tape conductor to rebar	22
Rl...	Stainless steel square clamps	49
RT...	Tee shape cable lugs	26
RUB302	"RUBERALU" Bitumen felt roll	52
RUBPROT30	Sealing tape	50
SEF...	Stainless steel cable holders	29
SEF.../2RBM	cable holders mounted with two bi-metallic washers	28
Sl...	Insulated clips for tape conductors	53
SIGTERPARA	Signal panel	50
SL...	Heavy duty bar holder	33
SLT-30	Copper alloy clips for tape conductors with a width of 30mm	53
SPCAI-M12	Clamp for tape conductor to fixed earth terminal	23
SPCAI-M10	Stainless steel square clamp	47
TFM...-A2	A2 Stainless steel threaded rod	34
THM...-A2	Threaded hexagonal A2 stainless steel screw	34
THM...-LAI	Copper alloy screw with hexagon head	35
TME...	Flexible earth braids	10-11-43
TPCIx	Stainless steel threaded M10 rod	47
TPE...	Flat tinned copper braided mesh	9
TPE...PVC	Flat tinned copper braided mesh, PVC Coated	8
TPM...A2	Stainless steel stove screw	29
TPM	Free standing air terminal support	47
TR...	Round conductors	15
TRE...	Round tinned copper braided mesh	9
TRE...PVC	Round tinned copper braided mesh, PVC Coated	8
VF34	Driving studs for threaded earth rods and coupling	17

Exothermic welding

20-CC...	Welding kit for 2 cable in parallel	60
20-CS...	Welding kit for cable on vertical steel surface	60
60-CC...	Exothermic welding kit for 2 cables in parallel	60
60-CS...	Exothermic kit for cable on vertical steel surface	60
BB...	30x2mm tape conductor weld	61
BB...	Mold for tape conductor of 30x3.5	62
BB...	Mold for tape conductor on tape conductor	72,73
BR...	Mold for tape conductor on earth rod	57
BS...	Mold for tape conductor on steel surface	74
CB...	Mold for cable on tape conductor	70,71
CC...	Mold for cable on cable	63 à 68
CR...	Mold for cable on earth rod	69
CRE...	Mold for cable on rebar	57
CS...	Mold for cable on steel surface	75,76
CX...	Mold for cable on rail	57
HC...	Handle clamp	59
KAL	Flint igniter	59
KBC	Card cloth brush	59
KCARTOUCHE	Universal butane tank for exothermic welding	59
KG...	Mold scraper	59
KGANT	Fireproof leather gloves with sleeves	59
KLAMPE	Blow torch piezo	59
KMAS	Sealing compound	59
KPC	Fine mold cleaning brush	59
KVISIERE	Protective facial screen	59
KW...	Exothermic powder	59

Find out more
about our entire product range on
www.maltep.com



MALTEP SAS

Z.I. - 3 rue de l'Artisanat
F-68420 HERRLISHEIM
Tel. + 33 3 89 86 44 40
Fax. + 33 3 89 86 44 41
contact@maltep.com



Discover our ESP's brands on www.sf-electric.com